

## Metal tube flowmeters Series SC250

### Variable area flowmeter for liquids, gases and steam

- Metallic or plastic tube with a robust construction
- Indication by means of magnetic coupling
- Scales calibrated in l/h, m<sup>3</sup>/h, kg/h, t/h, %, etc.
- High performance measurement in extreme working conditions and high resistance to corrosion
- Low pressure drop
- Fully hygienic design available
- Damping mechanism to avoid float bounces in gas and steam applications
- Flow measurement in horizontal pipes with the model SC250H and in vertical pipes with downwards or upwards flow (to increase the flow capacity) with the model SC250V
- Flow rate (model SC250):
  - Water: 2.5 l/h ... 180 m<sup>3</sup>/h
  - Air: 75 NI/h ... 5400 Nm<sup>3</sup>/h
- Accuracy: 2.5% (q<sub>G</sub>=50%) / 1.6% (q<sub>G</sub>=50%) on request
- Connections:
  - Model SC250: DN15 ... DN150
  - Models SC250H ... V / SM250: DN15 ... DN80
  - EN 1092-1 or ANSI flanges. Other flange standards on request (JIS,...)
  - Threaded connections BSP or NPT
  - Sanitary connections according to ISO 2852, SMS 1145, DIN 11851, TRI-CLAMP®
- Materials: EN 1.4404 (AISI 316L), PVC, PP, PTFE, Titanium, Hastelloy
- Local indication
- Options:
  - 1 or 2 limit switches
  - Electronic transmitter with 4-20 mA analog output for safe or hazardous area (Ex ia IIC T4 or T6 protection, ATEX certified). HART protocol available on request
  - Local volume totalizer. Remote volume totalizer by means



## Working principle

Flowmeters based in the variable area principle. audalímetros basados en el principio de área variable. The metering system consists on a calibrated orifice and a conical float. The force from the fluid, as it flows from the bottom to the top, displaces the float until it reaches an equilibrium point that is a function of:

- E = force of the fluid flow
- Pf = weight of the float
- Al = free area of flow  
(Al = Ao, calibrated orifice area, - Af, float area)

Each float position represents an area between the float and the orifice. This area corresponds to a flow rate.

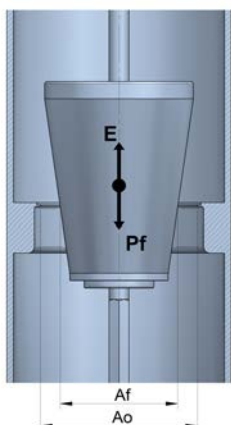

Ao= calibrated orifice area  
Af= float area  
Pf= weight of the float  
E= force of the fluid flow  
Al= Ao-Af= free area of flow

## Applications

- Water treatment plants, pulp & paper and food industry
- Pharmaceutical, chemical and petrochemical industry
- Power plants and nuclear generating plants
- Heating and cooling circuits
- Saturated steam circuits
- Oven treatments and control of gas burners

## Models

- SC250 upwards flow direction
- SC250H horizontal flow direction
- SC250V downwards flow direction or upwards flow direction with increased flow capacity
- SM250 for fluids with high viscosity

## Model SC250

### Technical data

- **Accuracy**, acc. to VDI/VDE 3513 sheet 2 ( $q_G=50\%$ ):  
2.5% / 1.6% on request
- **Direct scales in engineering units or in %**
- **Scale range:** 10:1
- **Fluid density:** no restrictions
- **Fluid viscosity:** up to 10 mPa·s approx., depending on flow rate

### • Fluid temperature:

- EN 1.4404 (AISI 316L): -50°C ... +300°C  
For higher temperatures, see thermal separator p. 11
- PTFE: -20°C ... +150°C
- PVC: 0°C ... +50°C
- PP: -5°C ... +90°C

### • Ambient temperature:

- EN 1.4404 (AISI 316L) & PTFE: -20°C ... +80°C
- PVC: 0°C ... +45°C
- PP: -50°C ... +80°C

### • Working pressure:

- SC250 / INOX (EN 1.4404 - AISI 316L):  
PN40 DN15 ... DN50  
PN16 DN65 ... DN150  
Others on request
- SC250 / PVC / PP / PTFE  
(AISI 316L tube, PVC / PP / PTFE lined):  
PN40 DN15 ... DN40  
PN16 DN50 ... DN125  
PN10 DN150  
Others on request
- SC250 / PVC T / PP T (Fully PVC / Fully PP): PN16

### • Connections:

- DN15 ... DN150 EN 1092-1 flange or ANSI equivalent. Other flange standards on request (JIS,...)
- Threaded connections BSP or NPT
- Sanitary connections according to ISO 2852, SMS 1145, DIN 11851, TRI-CLAMP®.  
Fully hygienic design available on request

- **Housing:** IP65 - coated aluminium. IP65 - PP or IP67 - EN 1.4404 (AISI 316L) with glass window, on request

## Operation

- **Vertical with upwards flow (BD)**

## Limit switches and transmitters

- **SC-AMM1 ... 2:** 1 or 2 adjustable micro-switches
- **SC-AMD1 ... 2:** 1 or 2 adjustable inductive detectors  
(+ relays on request)
- **TH7 ... TH7H:** 4-20 mA transmitter 2 wires + pulse output. HART protocol with model TH7H
- **TH7T ... TH7TH:** 4-20 mA transmitter + totalizer 2 wires + pulse output. HART protocol with model TH7TH
- **TH7 Ex ... TH7H Ex:** 4-20 mA transmitter 2 wires Ex ia IIC T4 or T6 (ATEX). HART protocol with model TH7H Ex
- **TH7T Ex ... TH7TH Ex:** 4-20 mA transmitter + totalizer 2 wires Ex ia IIC T4 or T6 (ATEX). HART protocol with model TH7TH Ex

## Float types



DN15 ... DN80

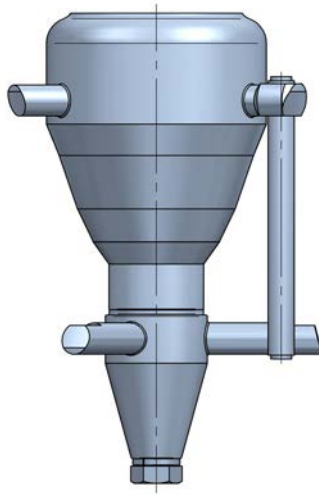

DN100 ... DN150



The tapered floats are constructed in AISI 316L, PVC, PP and PTFE as standard or other materials on request, according to the characteristics of the process fluid.

The maximum working viscosity for these floats is 10 mPa·s approx., depending on flow rate.

## Materials

N°	Description	Materials		
		EN 1.4404	PVC / PP	PTFE
1	Enclosure	Coated aluminium		
2	Window	Polycarbonate (UV resistant)		
3	O-rings	NBR		
4	Flange seat	EN 1.4404	PVC / PP	PTFE
5	Float	EN 1.4404	PVC / PP	PTFE
6	Flow tube	EN 1.4404	PVC / PP	PTFE/SS
7	Flanges	EN 1.4404	PVC / PP	EN 1.4404

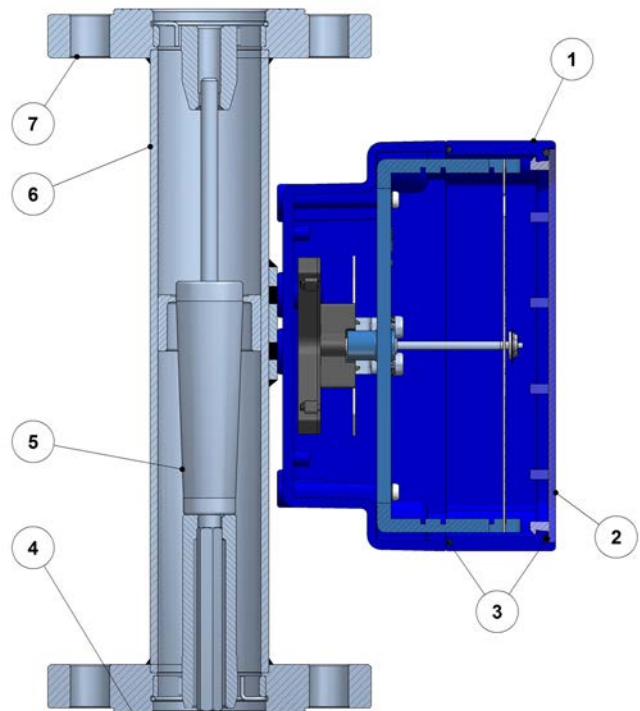

## Dimensions

### EN 1092-1 flanges (dimensions in mm)

DN	PN	Ø D	Ø k	Ø g	Ø l x n	B	A		C max		L	Weight kg
							SC250	SM250	SC250	SM250		
15	40	95	65	49	14 x 4	16	133	136	45	45	250	3,5
25	40	115	85	68	14 x 4	18	146	154	45	45	250	4,5
40	40	150	110	88	18 x 4	18	154	167	45	45	250	7,3
50	40	165	125	102	18 x 4	20	167	176	45	45	250	8,3
65	16	185	145	122	18 x 8	18	176	192	45	45	250	10
80	16	200	160	138	18 x 8	20	192	211	45	45	250	12
100	16	220	180	158	18 x 8	20	211	-	45	-	250	15
125	16	250	210	188	18 x 8	22	236	-	45	-	250	20
150	16	285	240	212	22 x 8	22	262	-	45	-	300	32

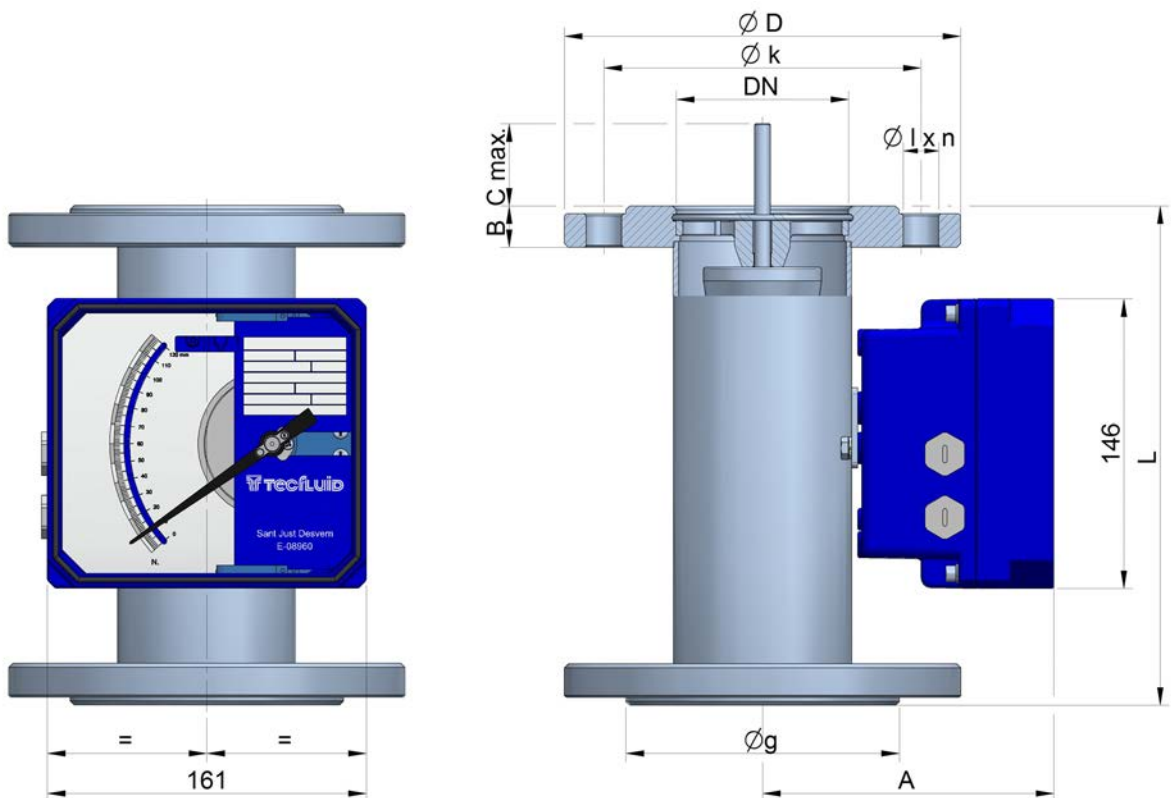

### ANSI flanges (dimensions in mm)

DN	Pressure class lbs	Ø D	Ø k	Ø g	Ø l x n	B	A		C max		L	Weight kg
							SC250	SM250	SC250	SM250		
½"	150	88,9	60,3	44,0	15,90 x 4	11,1	122	122	45	45	250	3,5
¾"	150	98,4	69,8	42,9	15,90 x 4	12,7	133	146	45	45	250	4,5
1"	150	107,9	79,4	50,8	15,90 x 4	14,3	146	154	45	45	250	7,3
1 ¼"	150	117,5	88,9	63,5	15,90 x 4	15,9	146	154	45	45	250	8,3
1 ½"	150	127,0	98,4	73,0	15,90 x 4	17,5	154	167	45	45	250	10
2"	150	152,4	120,6	92,1	19,05 x 4	19,1	167	176	45	45	250	12
2 ½"	150	177,8	139,7	104,8	19,05 x 4	22,2	176	192	45	45	250	15
3"	150	190,5	152,4	127,0	19,05 x 4	23,8	192	211	45	45	250	20
4"	150	228,6	190,5	157,2	19,05 x 8	23,8	211	-	45	-	250	32
5"	150	254,0	215,9	185,7	22,20 x 8	23,8	236	-	45	-	250	20
6"	150	279,4	241,3	215,9	22,20 x 8	25,4	262	-	45	-	300	32

**Flow ranges**

Size DIN (ANSI)	Float N°	Flow scales			Flow scales			
		EN 1.4404 (AISI 316L) float (7.95 g/cm³)			PVC float			
		l/h water	Nm³/h air 1.013 bar abs 20°C	ΔP mbar	l/h water	ΔP mbar	Nm³/h air 1.013 bar abs 20°C	ΔP mbar
15 (½")	15025	2.5-25	0.07-0.7	40	2.5-25	20	0.1-1	30
	15040	4-40	0.12-1.2	40	6-60	15	0.2-2	25
	15060	6-60	0.18-1.8	40	10-100	15	0.4-4	25
	15100	10-100	0.3-3	40	16-160	15	0.6-6	25
	15160	16-160	0.5-5	50	25-250	15	1-10	25
	15250	25-250	0.7-7.5	50	40-400	15	1.6-16	25
15 (¾")	15400	40-400	1.2-12	50	60-600	15	2-20	25
	15600	60-600	1.8-18	50				
	15800 *	80-800 *	2.4-24 *	60 *				
25 (1")	25100	100-1000	3-30	60	16-160	10	0.6-6	20
	25160	160-1600	5-50	70	25-250	10	1-10	20
	25250	250-2500	7-75	90	40-400	10	1.6-16	20
	25400	400-4000	12-120	110	60-600	10	2.5-25	20
	25101				100-1000	10	4-40	20
	25161				160-1600	10	6-60	20
	25251				240-2400	10	9-96	20
40 (1 ½")	40400	400-4000	12-120	45	150-1500	20	5-50	25
	40600	500-6300	15-180	55	250-2500	20	8-80	25
	40800	800-8000	24-240	90	400-4000	20	14-140	25
	40100 *	1000-10000 *	30-300 *	120 *				
50 (2")	50800	800-8000	24-240	70	250-2500	15	9-90	25
	50100	1000-10000	30-300	90	400-4000	15	15-150	25
	50150	1500-15000	45-450	100	600-6000	15	20-200	25
	50200 *	2000-20000 *	60-600 *	130 *				
	50101				1000-10000	15	35-350	25
65 (2 ½")	65150	1500-15000	45-450	70	800-8000	15	25-250	25
	65200	2000-20000	60-600	100	1000-10000	15	40-400	25
	65300 *	3000-30000 *	90-900 *	140 *				
80 (3")	80020	2000-20000	60-600	80	1000-10000	15	40-400	25
	80025	2500-25000	75-750	100	1600-16000	15	60-600	25
	80030	3000-30000	90-900	120				
	80040 *	4000-40000 *	120-1200 *	160 *				
	80050 *	5000-50000 *	150-1500 *	190 *				
	80060 *	6000-60000 *	180-1800 *	220 *				
100 (4")	81040	4000-40000	120-1200	100	1600-16000	20	60-600	25
	81050	5000-50000	150-1500	120	2000-20000	20	100-1000	25
	81060	6000-60000	180-1800	150				
	81085 *	8500-85000 *	260-2600 *	190 *				
	81095 *	10000-95000 *	300-2900 *	220 *				
125 (5")	82080	8000-80000	240-2400	120	3000-30000	20	150-1500	30
	82100	10000-100000	300-3000	150	4000-40000	20	200-2000	30
	82120	12000-120000	360-3600	180	6000-60000	20	220-2200	30
150 (6")	83150	15000-150000	450-4500	220	8000-80000	25	250-2500	35
	83180	18000-180000	500-5400	220	10000-100000	25	300-3200	35

\* Special flow ranges. Please consult factory

## Models SC250H ... V

The SC250H...V are versions of the SC250 flowmeter that can be installed in horizontal pipes with flow from left to right or right to left, in vertical pipes with downwards flow or in vertical pipes with upwards flow to increase the standard flow capacity.

## Working principle

The metering system is made up of a calibrated orifice, a conical float and a spring.

The force from the fluid, as it flows through the flowmeter, displaces the float and compresses the spring, reaching an equilibrium point which corresponds to a specific flow.

## Technical data

The accuracy is 2.5% ( $q_G=50\%$ ) or optionally 1.6% ( $q_G=50\%$ ) according to VDI / VDE 3513 sheet 2.

The SC250H...V is suitable for the flow measurement of liquids or gases and can be equipped with additional switches, transmitters and options like the SC250 series.

The standard materials for the floats are PVC, PP, PTFE and EN 1.4404 (AISI 316L). Versions for high pressure and temperature applications are also available.

For more details about pressure and temperature limits, materials, etc. please refer to model SC250.

## Operation

- **Vertical, with SC250V:**
  - Upwards flow (BD)
  - Downwards flow (DAB)
- **Horizontal, with SC250H:**
  - Left to right flow (ED)
  - Right to left flow (DES)

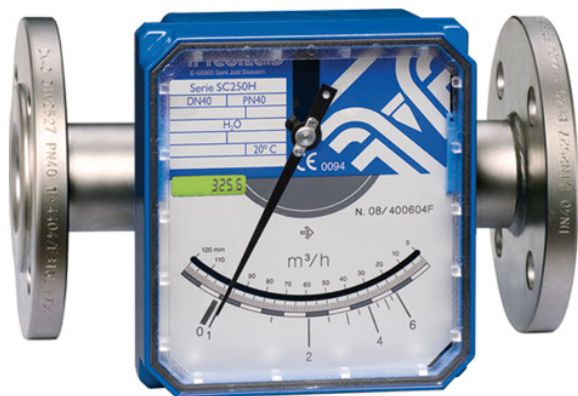

<sup>(1)</sup> Flow ranges available only with plastic float (PP / PVC / PTFE)

Other flow ranges available, with different float materials

Scales for air, liquids or gases available

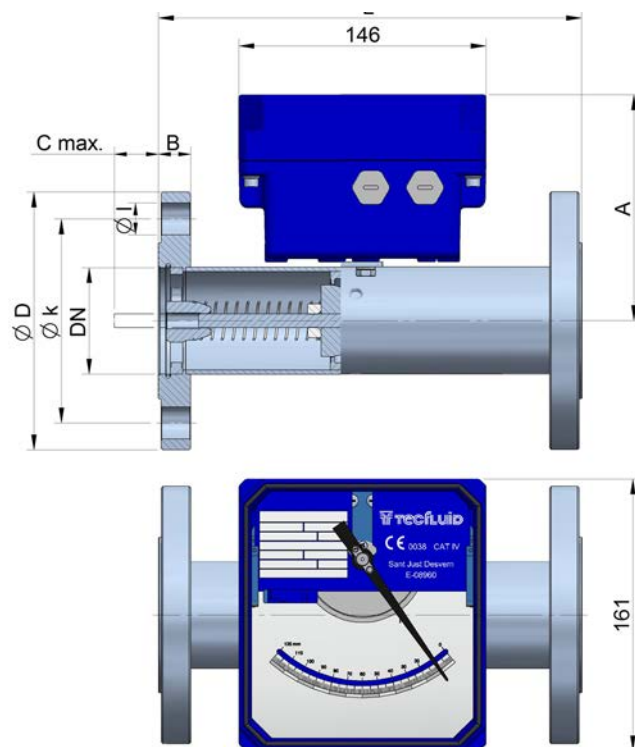

Please refer to p. 5 for dimensions

## Flow ranges

Size DIN (ANSI)	Flow scales l/h water			$\Delta p$ mbar
	Spring n° 1	Spring n° 2	Spring n° 3	
15 (½")	10-100			390
	16-160	25-250		290
	25-250			290
	40-400	60-600		200 / 350
15 (¾")	100-1000			350
	150-1500	250-2500		350 / 600
	60-600 <sup>(1)</sup>			90
	100-1000 <sup>(1)</sup>			90
25 (1")	160-1600	250-2500		290
	400-4000			290
	600-6000			290
	800-8000 <sup>(1)</sup>			120
40 (1 ½")	1000-10000			300
	400-4000 <sup>(1)</sup>			90
	650-6500	800-8000		130 / 160
	1000-10000	1600-16000	2000-20000	180 / 270
50 (2")	600-6000			120
	1100-11000			120
	1800-18000			150
	2300-23000*	3000-30000*	4000-40000	170* / 280
65 (2 ½")	1800-18000			110
	2400-24000*	3000-30000*	4000-40000	150* / 220
80 (3")	2500-25000 <sup>(1)</sup>	3000-30000 <sup>(1)</sup>		50 / 60
	4000-40000	5000-50000		140
	6000-60000			220

## Metal tube flowmeters

### Series SC250

#### Model SM250

The SM250 is a version of the SC250 flowmeter that is suitable for liquids with high viscosities, which cannot be measured with the standard SC250. This is achieved thanks to its internal design and special floats.

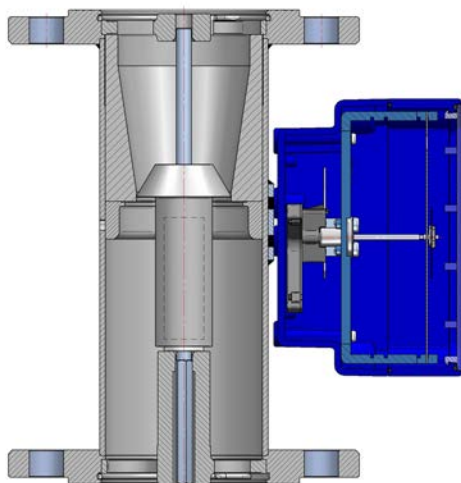

#### Working principle

The metering system consists of a conical tube and a special T or V float. In this model, there is no calibrated orifice inside the tube. The force from the fluid, as it flows from the bottom to the top, displaces the float until it reaches an equilibrium point.

#### Technical data

The standard accuracy is 1.6% ( $q_E=50\%$ ).

This model can be equipped with the same electronic devices and accessories as the model SC250. The standard material is EN 1.4404 (AISI 316L) for both the flow tube and the float. Plastic versions (PP, PVC, PTFE) and special instruments for high pressure and temperature applications are also available on request.

For more details about pressure and temperature limits, materials, etc. please refer to model SC250.

#### Operation

- Vertical with upwards flow (BD)

#### Flow ranges

Size DIN (ANSI)	Flow scales EN 1.4404 float (7.95 g/cm <sup>3</sup> ) l/h water		$\Delta p$ mbar	
	Type T	Type V	Type T	Type V
	15 (1/2")	6-60 12-120 16-160		55 55 55
15 (3/4")	25-250	30-300	55	55
	25-250	30-300	55	55
	40-400	50-500	55	55
	60-630	80-800	55	55
	80-800	100-1000	60	60
25 (1")	25-250	30-300	60	70
	40-400	50-500	60	70
	60-630	80-800	60	70
	80-800	100-1000	60	70
	100-1000	130-1300	60	70
	120-1200	160-1600	70	80
	160-1600	200-2000	70	100
40 (1 1/2")	200-2000	250-2500	90	120
	250-2500	300-3000	110	160
	300-3000	400-4000	45	60
	400-4000	500-5300	45	60
	500-5000	650-6500	45	60
50 (2")	600-6000	800-8000	45	60
	750-7500	1000-10000	55	80
	1000-10000	1300-13000	70	100
65 (2 1/2")	600-6000	800-8000	50	60
	750-7500	1000-10000	50	60
	1000-10000	1300-13000	55	80
80 (3")	1000-10000	1300-13000	60	80
	1200-12000	1500-15000	60	80
	1600-16000	2000-20000	60	80
	2000-20000	2500-25000	80	100

#### Float types

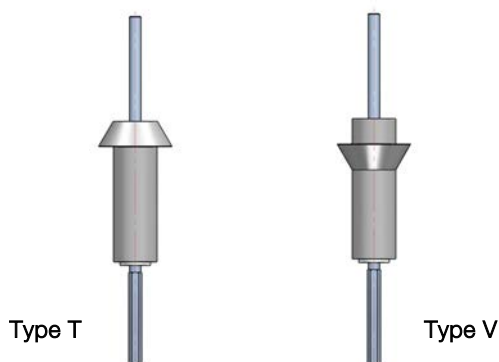

The constant section T & V floats are constructed in AISI 316L, PVC, PP & PTFE as standard or other materials on request, according to the characteristics of the process fluid.

## Limit switches

### Adjustable limit switch SC-AMM



Electrical micro-switch mounted in the indicator housing.

- SC-AMM1 ... 2: 1 ... 2 adjustable limit switches
- Ratings: 3(1) A, 250 V (VDE/CEE)
- Hysteresis:  $\pm 10\%$  of full scale value
- Ambient temperature:  $-25^{\circ}\text{C}$  ...  $+80^{\circ}\text{C}$
- Mechanical life:  $10^7$  operations
- ATEX certificate Ex ia IIC T6

Gold plated contacts on request.

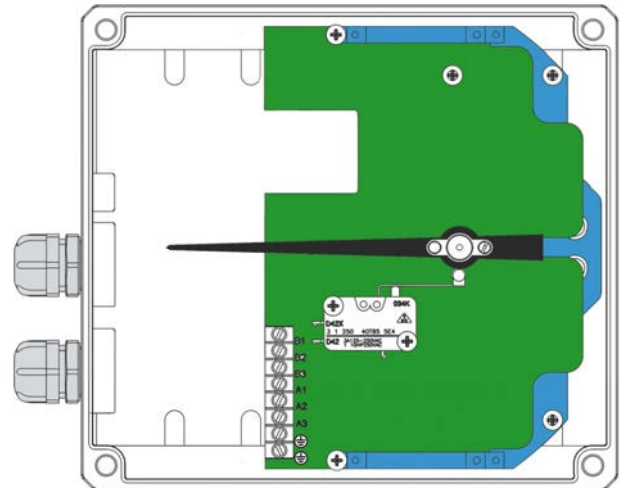

SC-AMM

### Adjustable limit switch SC-AMD



NAMUR (EN 60947-5-6) 3.5 mm slot type inductive detector activated by vane, mounted in the indicator housing.

- SC-AMD1 ... 2: 1 ... 2 adjustable limit switches
- Power supply: 8 VDC
- Ambient temperature:  $-25^{\circ}\text{C}$  ...  $+70^{\circ}\text{C}$
- ATEX certificate Ex ia IIC T6

#### Control relay (on request)

NAMUR (EN 60947-5-6) for 1 or 2 inductive detectors.

- Power supply: 24 ... 253 VAC 50-60 Hz  
24 ... 300 VDC
- Input: NAMUR Ex ia IIC
- Output: 1 or 2 relay contacts
- Output rating: 2 A 250 VAC 100 VA / 1 A 24 VDC
- Ambient temperature:  $-20^{\circ}\text{C}$  ...  $+60^{\circ}\text{C}$

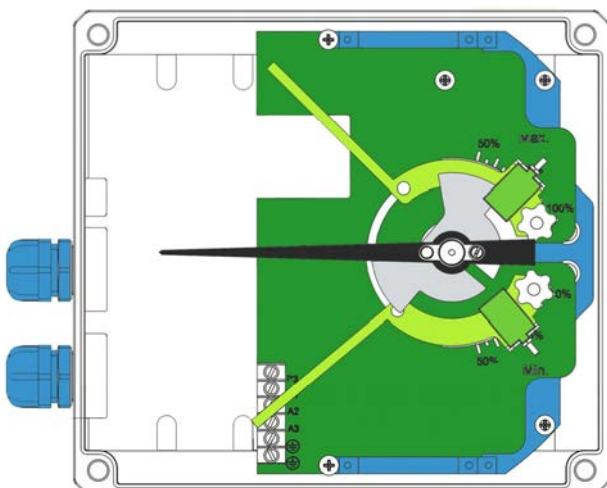

SC-AMD

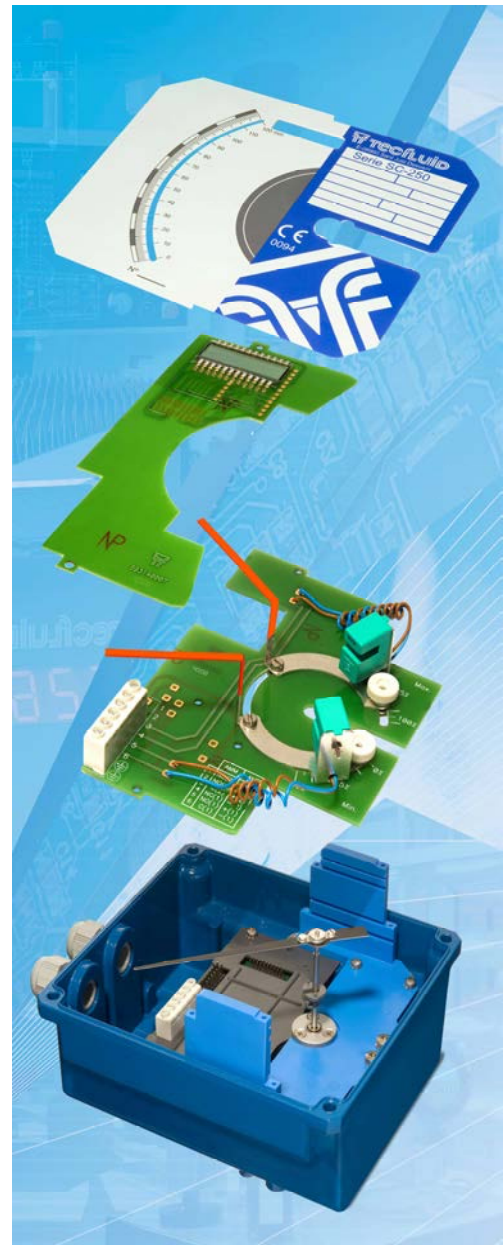

Modular housing



## Metal tube flowmeters Series SC250

### Transmitters and totalizers



#### Transmitter TH7

The TH7 electronic transmitters provide an analog output proportional to the flow rate and a digital output selectable either as a pulse or an alarm output (except for the Ex versions). They can also include a display for volume totalization. They are based on the Hall effect and mounted inside the indicator housing.

- TH7 transmitter
- TH7H transmitter + HART protocol
- TH7T transmitter + totalizer
- TH7TH transmitter + totalizer + HART protocol

#### Technical data

- Power supply: 12 ... 36 VDC, 2-wire system
- Power consumption: 4-20 mA for 0 ... 100% of scale
- 4-20 mA analog output:
  - Error: < 0.6% of the magnet position
  - Maximum load in 4-20 mA loop: 1.1 k $\Omega$  (with 36 VDC power supply)
- Digital output: Potential free N channel MOSFET,  $I_{max}$  200 mA, for either pulse or alarm output:
  - Pulse output:
    - Max. frequency 6 Hz
    - Pulse duration approx. 62.5 ms
  - Alarm output, adjustable in one point of the scale. Programmable by means of Winsmeter TH7 software
- Totalizer: 8 digits, 4.5 mm high  
Reset by potential free contact
- Ambient temperature: -5°C ... +70°C
- Easy programmable by means of Tecfluid's Winsmeter TH7 software, available for download at [www.tecfluid.com](http://www.tecfluid.com)

#### ATEX version (Ex ia IIC T4 or T6)

#### Technical data

- ATEX certificate Ex II 1 GD
- Power supply: 14 ... 30 VDC, 2-wire system
- Power consumption: 4-20 mA for 0 ... 100% of scale
- 4-20 mA analog output:
  - Error: <0.6% of the magnet position
  - Maximum load in 4-20 mA loop: 900  $\Omega$  (with 30 VDC power supply)
- Totalizer: 8 digits, 4.5 mm high  
Reset by potential free contact
- Ambient temperature: -5°C ... +40°C

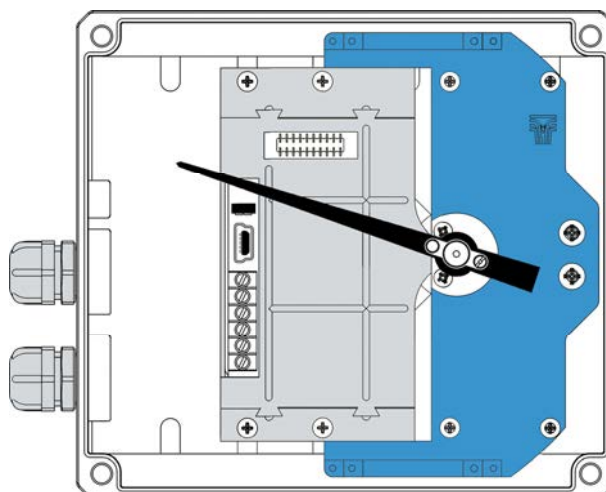

TH7

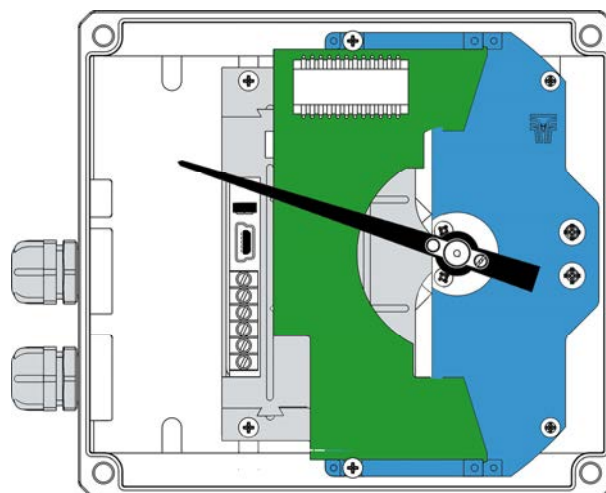

TH7T

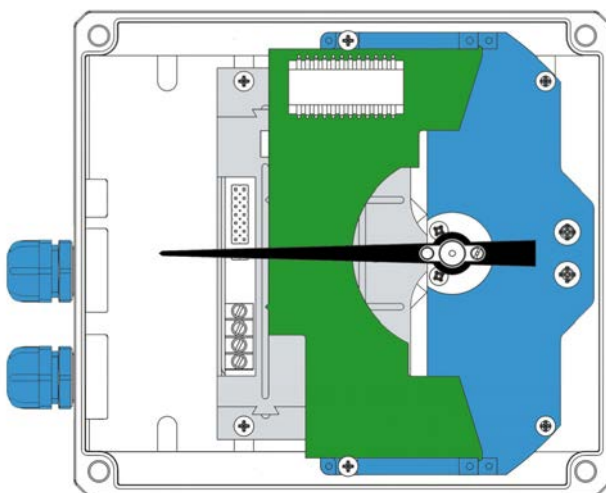

TH7T Ex

Both limit switches AMM or AMD and electronic transmitters TH7 or TH7T can be mounted together in the same housing.

The TH7 Ex and TH7T Ex transmitters belong to group II. They are intended for use in potentially explosive atmospheres, except in mining

## Models SC250 – other connection types

### Sanitary connection DIN 11851 (EN 1.4404)

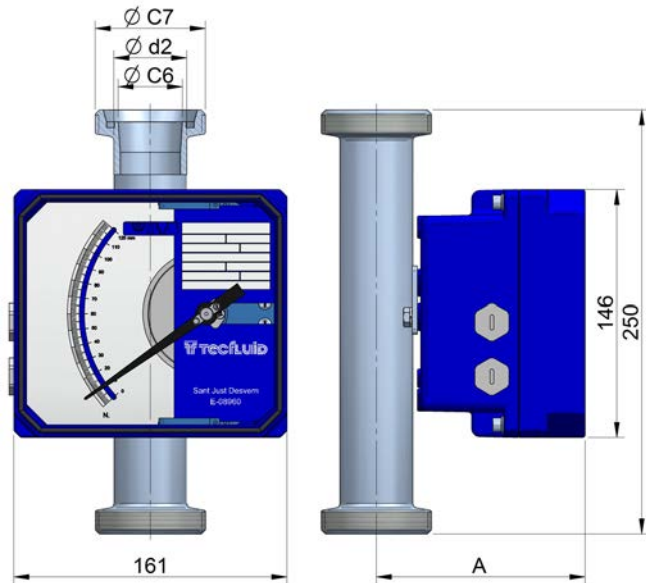

NW - DN	15	25	40	50	65	80	100
Ø C <sub>7</sub>	Rd 34	Rd 52	Rd 65	Rd 78	Rd 95	Rd 110	Rd 130
	x 1/8"	x 1/6"	x 1/6"	x 1/6"	x 1/6"	x 1/4"	x 1/4"
Ø C <sub>6</sub>	17	24.8	35.6	45.8	67	82.8	100
Ø d <sub>2</sub>	21.3	30	42	51	73	88.9	108
A	114	118	124	129	140	148	157
DIN EQ.	15(PC)*	15	25	40	50-65	80	100

\* Max flow rate 250 l/h H<sub>2</sub>O

### Sanitary connection SMS 1145 (EN 1.4404)

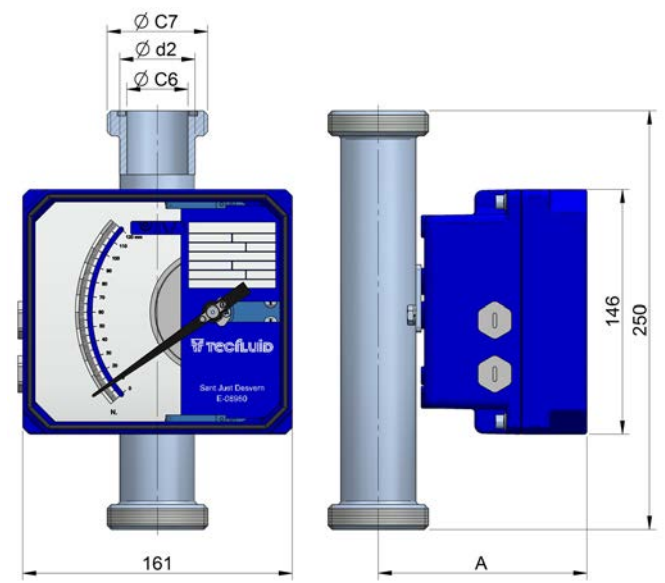

NW - DN	15	25	40	50	65	100
Ø C <sub>7</sub>	40	60	70	85	98	125
Ø C <sub>6</sub>	22.5	35.5	48.5	60.5	72	100
Ø d <sub>2</sub>	25	42	51	63.5	73	108
A	115	124	129	135	140	157
DIN EQ.	15	25	40	50	65	100

### Sanitary connection CLAMP ISO 2852 (EN 1.4404)

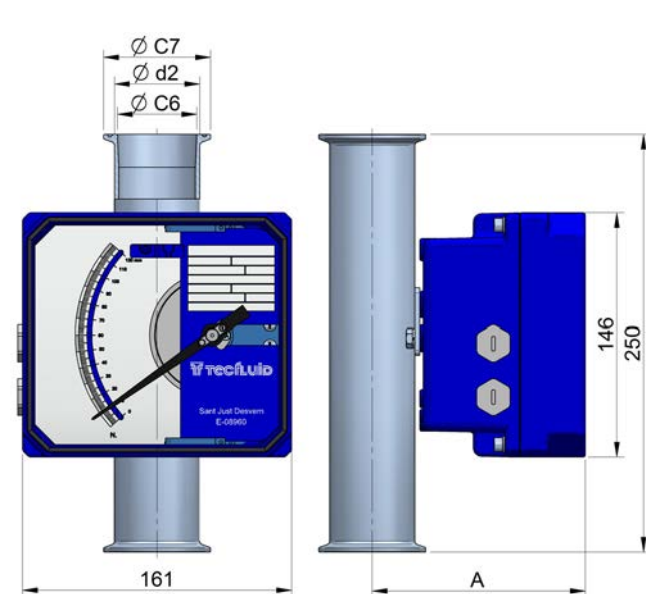

Ø C <sub>7</sub>	34	50.5	50.5	64	77.5	91	106	130
Ø C <sub>6</sub>	17	24.8	35.6	45.8	58.3	67	82.8	100
Ø d <sub>2</sub>	21.3	30	42	51	63.5	73	88.9	108
A	114	118	124	129	135	140	148	157
DIN EQ.	15(PC)*	15	25	40	50	65	80	100

\* Max flow rate 250 l/h H<sub>2</sub>O

### Threaded connection BSP / NPT (EN 1.4404)

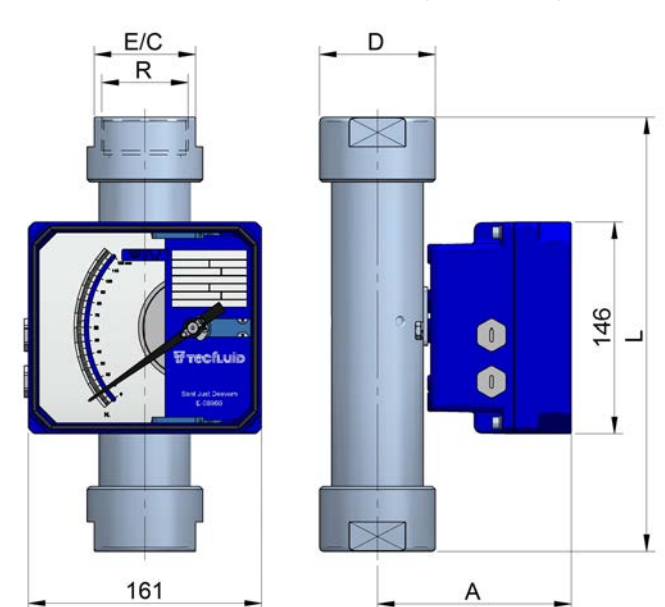

R	1/2"	3/4"	1"	1 1/2"	2"	2 1/2"	3"	4"
L	275	275	285	300	300	310	310	310
D	35	40	50	65	80	90	110	130
A	114	118	124	129	135	140	146	156
E/C	30	35	45	60	70	84	104	124
DIN EQ.	15 (PC)*	15	25	40	50	65	80	100

\* Max flow rate 250 l/h H<sub>2</sub>O

## Metal tube flowmeters

### Series SC250

#### Accessories

##### Thermal separator

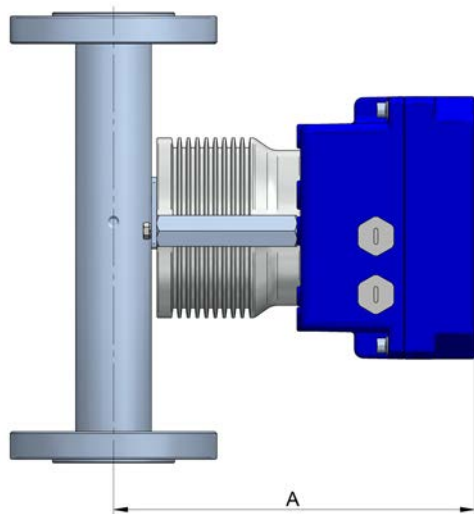

DN	15	25	40	50	65	80	100	125	150
A	177	183	187	194	198	207	216	228	241

- Standard in aluminium, optional in EN 1.4404 (AISI 316L)
- For working with fluids at high and low temperatures
- With electronics
  - DN15 ... DN65: -180°C ... +300°C
  - DN80 ... DN150: -180°C ... +260°C
- Without electronics: DN15 ... DN150: -180°C ... +400°C
- Reference ambient temperature: 20°C

##### Explosion proof enclosure Ex d IIC T6

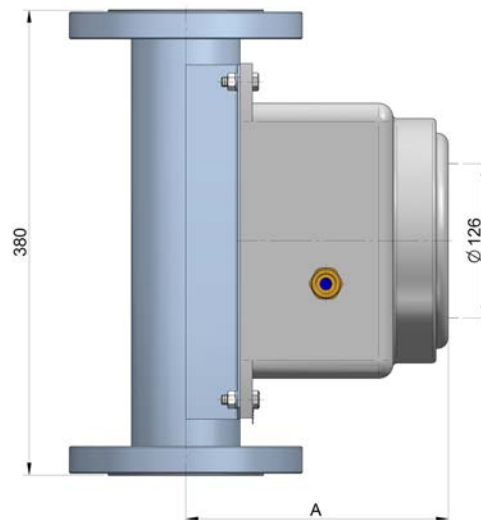

DN	15	25	40	50	65	80	100	125	150
A	195	201	205	212	216	224	234	246	260

- Porthole with glass for viewing the flow rate
- In the inside, the SC250 ... SM250 housing with standard limit switches and transmitters
- Explosion proof protection: Ex d IIC T6
- Ingress protection: IP65  
(Pending of certification)

##### Stainless steel housing

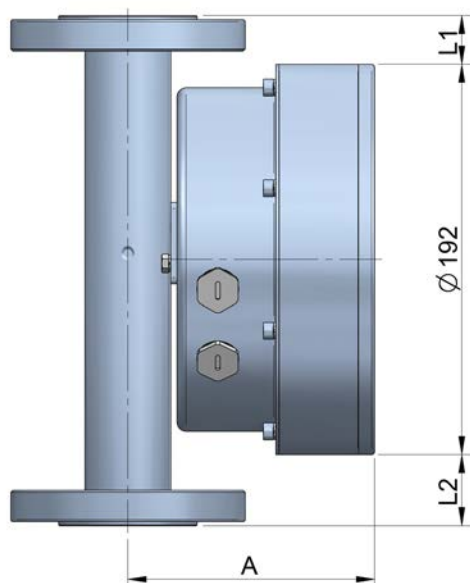

DN	15	25	40	50	65	80	100	125	150
L1	30	30	30	30	30	30	35	35	60
L2	40	40	40	40	40	40	35	35	60
A	115	121	125	132	137	145	154	167	180

- Specially indicated for working within sanitary or sterile installations, saline atmospheres (marine platforms), etc.
- All stainless steel construction EN 1.4404 (AISI 316L), with glass window
- Can fit standard limit switches and TH transmitters
- Ingress protection: IP67



## Float damping system (for gas and steam applications)

Ceramic, PEEK or metallic piston system for avoiding float oscillations in flowmeters for gas and steam service, obtaining stable readings even with very low working pressures and low gas densities.

Available for DN15 ... DN80

1. Upper float stop
2. Float
3. Piston
4. Piston locking circlip
5. Guide cylinder
6. Circlips for locking upper float stop & guide cylinder

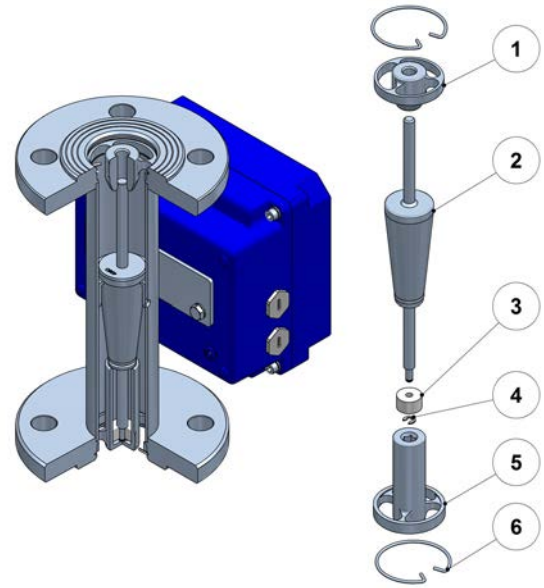

## Heating-cooling chamber

For installations that require maintaining the process fluid temperature by means of the circulation of a heating or cooling fluid through the double chamber of the flowmeter.

- Without contact with the process fluid
- Flanged or threaded pipe fittings (BSP, NPT, EN 1092-1)  
Other standards on request
- Pipe fitting diameters according to the table below
- Stainless steel EN 1.4404 (AISI 316L)  
Other materials on request

DN	15 (PC)	15	25	40	50	65	80	100	125	150
R	1/2"			3/4"			1"			
B*	DN15			DN20			DN25			
DR	35	39	45	50	50	56	70	80	91	104
DB	77	77	88	105	112	122	130	140	155	172

\* EN 1092-1 PN16 flange (others on request)

