

## Guided Radar level transmitters Series LTDR



### TDR Radar level transmitter for liquids



- 4-wire sensor with:
  - Single rod
  - Coaxial probe
  - Rope probe
- Fully modular probe design, i.e. the probe types are interchangeable without any special tools or welding
- Innovative signal analysis and disturbance signal suppression
- Complete galvanic insulation of device electronics from its inputs/outputs and the tank potential (no problems with electrochemical corrosion protection)
- Enables direct, precise and highly reliable continuous level measurement as well as point level detection combined in one device
- Suitable for almost every liquid. Exceptional performance in liquids with low dielectric constant (i.e. low reflectivity) such as oils and hydrocarbons
- Suitable for solids, mainly with rope probe version
- Independent of changing process conditions (density, conductivity, temperature, pressure,...)
- Suitable for small tanks, tall and narrow nozzles or other difficult tank geometries. Almost no installation restrictions
- Unmatched price / performance ratio
- Materials: EN 1.4404 (AISI316L)
- Measuring range:
  - Single rod probe: 100 ... 3000 mm
  - Coaxial probe: 100 ... 6000 mm
  - Rope probe: 100 ... 20000 mm
- 4-20 mA output & 1 x programmable transistor output for level switch
- HART™ Protocol included
- ATEX version available on demand



## Measurement principle

LTDR uses TDR (Time Domain Reflectometry) technology.

Low-energy, high-frequency electromagnetic impulses, generated by the sensor's circuitry, are propagated along the probe which is immersed in the liquid to be measured.

When these impulses hit the surface of the liquid, part of the impulse energy is reflected back up the probe to the circuitry which then calculates the fluid level from the time difference between the impulses sent and the impulses reflected.

The sensor can output the analyzed level as a continuous measurement reading through its analog output, or it can convert the values into freely positionable switching output signals.

LTDR Sensors are also known as Guided Radars or Guided Wave Radars.

## Applications

To meet the most application requirements, TECFLUID have three different probe types, detailed as follows:

### Single rod (fig. 1, 3) and rope probe (fig. 5)

- Suitable for a very wide range of applications and liquids.
- The signal has wider detection radius around the rod. Thus, it is more responsive for measurement signal disturbances which can be easily overcome by observing a few mounting considerations and making simple configuration adjustments to the sensor.
- The single rod probe is also recommended for installation in bypass chambers and stilling wells, which basically act together with the rod as a big coaxial probe.

### Coaxial probe (fig. 2, 4)

- The high frequency measurement signal is completely contained within the outer tube.
- Immune against any external conditions and interfering objects outside its tube.
- Ideal solution for a hassle-free "drop-in anywhere" installation, ensuring reliable measurement under almost any application condition.
- Ideal choice for measuring low reflectivity liquids (i.e. low dielectric constant) such as oils and hydrocarbons.
- Recommended for the use with clean liquids only.
- NOT recommended with viscous, crystallizing, adhesive, coating or sticky liquids, fibrous liquids, sludge, slurry, pulp or any liquids containing solid particles. Such liquids might cause build-up, bridging or clogging inside the coaxial probe.

Fig. 1. Single rod probe

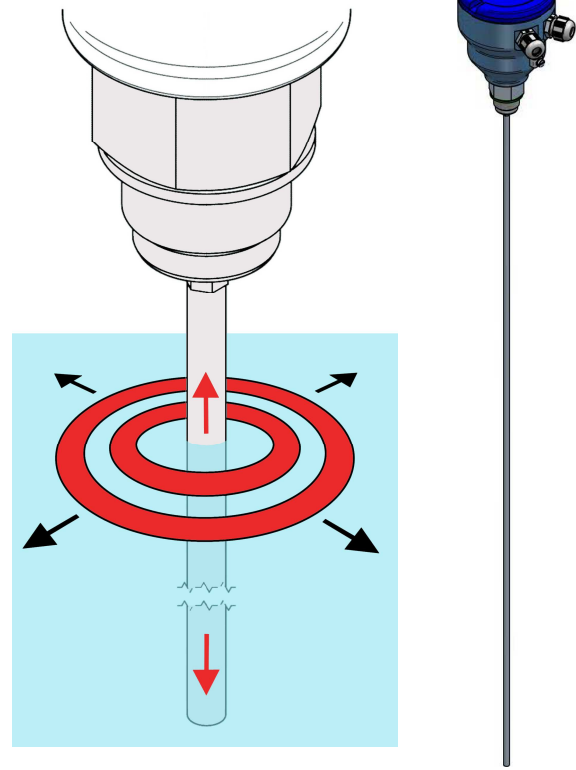
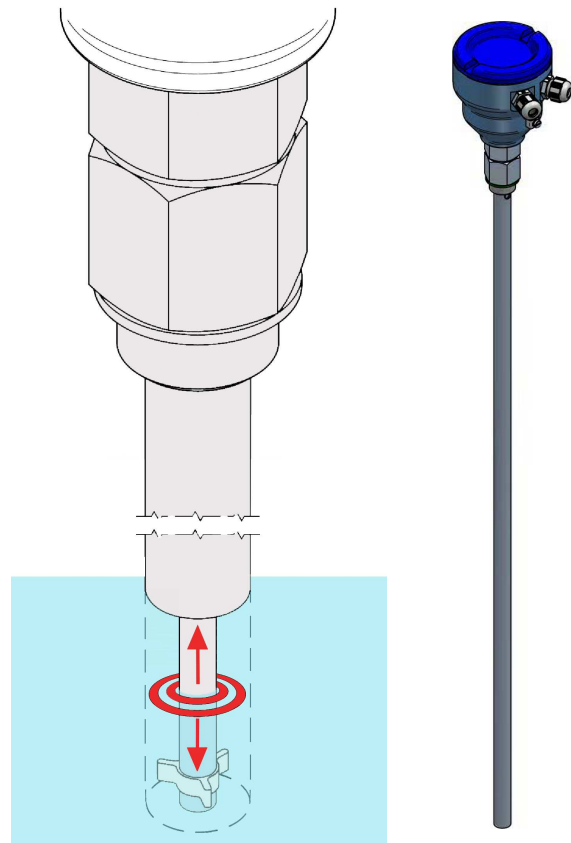

Fig. 2. Coaxial probe



## Technical data

### Mechanical specifications

- Material exposed to tank atmosphere:
  - Single rod probe: 1.4404 / 316L and PEEK™
  - Coaxial probe: 1.4404 / 316L, PEEK™
    - O-ring seal: EPDM or FKM (Viton®)
    - (other o-ring materials on request)
  - Rope probe: 1.4404 / 316L and PEEK™
- Gasket at connection thread: Klingsil® C-4400, 2 mm thick
- Housing materials:
  - Housing body and cover: aluminium alloy
  - Other materials on request
  - Cover o-ring seal: NBR or silicone rubber
  - Other o-ring materials on request
- Housing rating: IP68 10 m H<sub>2</sub>O, NEMA6P
- Cable entries:
  - Standard version: 2 cable entries M16x1.5
  - ATEX version: 2 cable entries M20x1.5
 Other dimensions on request
- Connection thread (CT): G<sup>3/4</sup>A (wrench size 32 mm)
- Other connections on request
- Weight:
  - Standard housing, assembled with electronics and feedthrough: 1240 g
  - Standard housing (empty): 940 g
  - ATEX housing, assembled with electronics and feedthrough: 950 g
  - ATEX housing (empty): 650 g
  - Electronics: 70 g
  - Feedthrough: 220 g
  - Single rod probe, 1m: 230 g
  - Complete coaxial probe, 1m: 770 g
  - Coaxial tube (not assembled), 1m: 540 g
  - Set of parts for attaching coaxial tube: 130 g

### Application specifications

- Dielectric constant ( $\epsilon_r$ ):
  - Single rod probe: > 1.8
  - Coaxial probe: > 1.4
  - Rope probe: > 1.8
- Conductivity & density: no restrictions
- Dynamic viscosity:
  - Single rod probe: < 5000 mPa·s = 5000 cP
  - Coaxial probe: < 500 mPa·s = 500 cP
  - Rope probe: < 5000 mPa·s = 5000 cP
- Application temperature: -40°C ... +150°C
- Ambient temperature:
  - Operation: -25°C ... +80°C
  - Storage: -40°C ... +85°C
- Application pressure: -1 bar ... 40 bar
- Velocity of level change: < 1000 mm/s

### Measurement specifications

- Accuracy:  $\pm 3$  mm
- Repeatability: < 2 mm
- Resolution: < 1 mm
- Probe type:
  - Single rod  $\varnothing 6$  mm
  - Coaxial  $\varnothing 17.2$  mm (standard tube: NPS  $\frac{3}{8}$ " 10S)
  - Rope  $\varnothing 4$  or  $\varnothing 6$  mm
- Probe length (L):
  - Single rod probe: 100 ... 3000 mm
  - Coaxial probe: 100 ... 6000 mm
  - Rope probe: 100 ... 20000 mm
 Can be ordered in 1 mm increments
- Inactive area:
  - Top (I1):
    - Single rod probe:  $\epsilon_r=80$ : 50 mm /  $\epsilon_r=2$ : 50 mm
    - Coaxial probe:  $\epsilon_r=80$ : 30 mm /  $\epsilon_r=2$ : 50 mm
    - Rope probe:  $\epsilon_r=80$ : 80 mm /  $\epsilon_r=2$ : 80 mm
  - Bottom (I2):
    - Single rod probe:  $\epsilon_r=80$ : 10 mm /  $\epsilon_r=2$ : 50 mm
    - Coaxial probe:  $\epsilon_r=80$ : 10 mm /  $\epsilon_r=2$ : 50 mm
    - Rope probe:  $\epsilon_r=20$ : 10 mm /  $\epsilon_r=2$ : 80 mm
- Measuring range (M): probe length less both inactive areas at top and bottom
- Switching point (S): freely positionable within measuring range

### Electrical specifications

- 4-wire system
- Electronics completely galvanically insulated from inputs/outputs and tank potential, thus avoiding any problems from electrochemical corrosion protection of the tank
- Output functions: continuous level measurement through analog output and point level detection through switching output
- Analog output (active): current output 4-20mA
  - Total load resistance: < 500  $\Omega$ : HART™ resistor approx. 250  $\Omega$  + load resistance approx. 250  $\Omega$ .
  - Lower range value: 4.0 mA (span 0%)
  - Upper range value: 20.0 mA (span 100%)
  - Response time: 0.5 s (default), 2 s, 5 s (selectable)
  - Temperature drift: < 0.2 mm/K in ambient temperature
- Switching output DC PNP (active): NC or NO (shortcircuit protected)
  - Load current: < 200 mA
  - Signal voltage HIGH: supply voltage -2V
  - Signal voltage LOW: 0V ... 1V
  - Response time: < 100 ms
- Supply voltage: 12 ... 30VDC (reverse-polarity protected)
- Current consumption: < 70 mA at 24VDC (no burden)
- Start up time: < 6 s
- Cable terminals:
  - Screwless, cage clamp terminal block for stranded and solid wires 0.5 ... 2 mm<sup>2</sup>
  - The usage of cable and sleeves with insulation collar is not recommended

## Dimensions

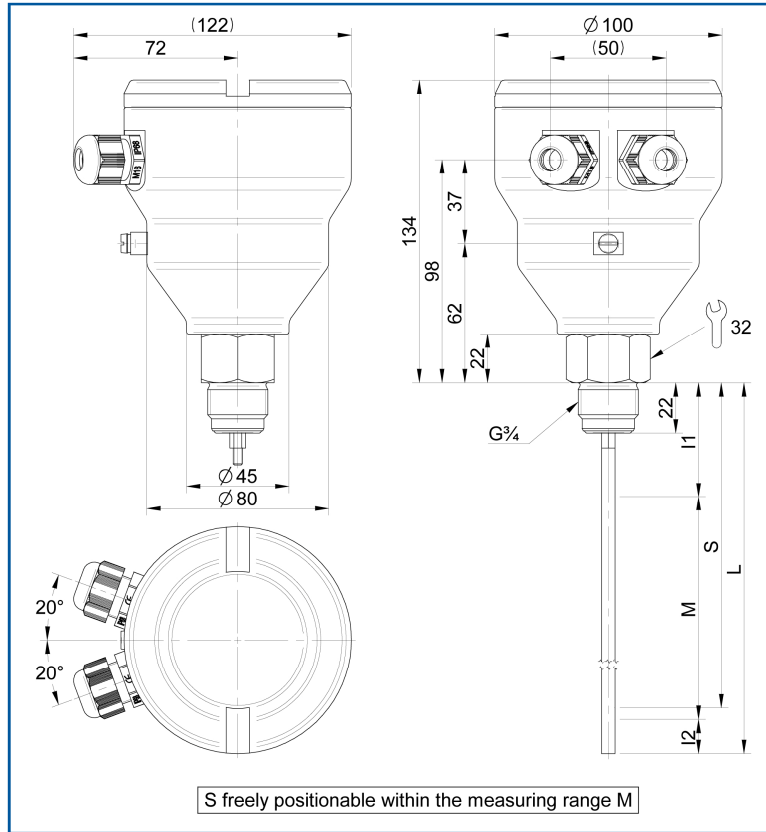

Fig. 3. Single rod probe

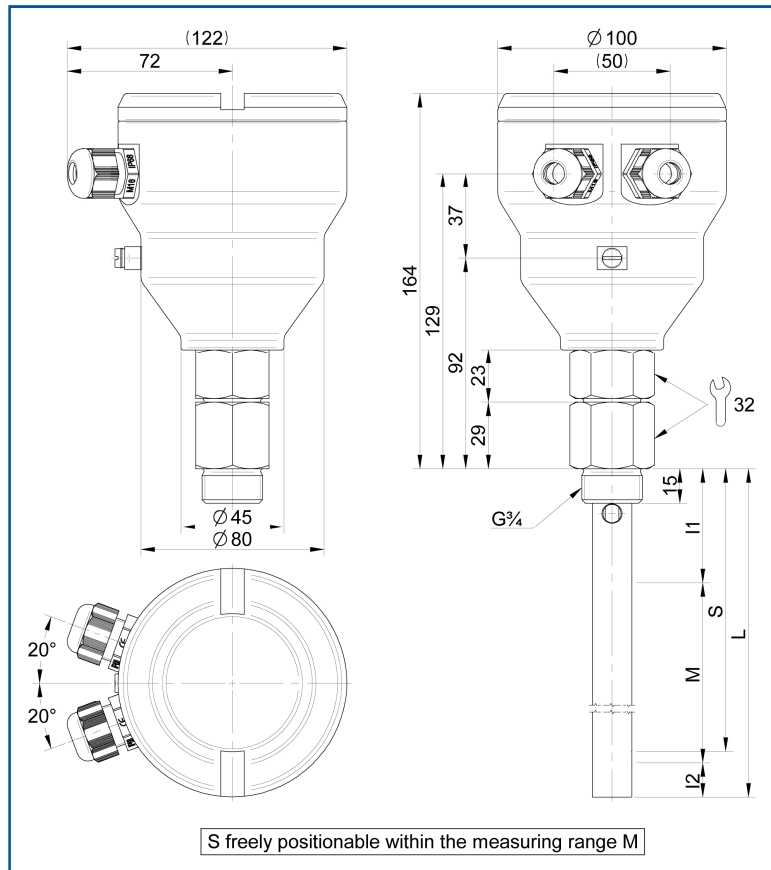

Fig. 4. Coaxial probe

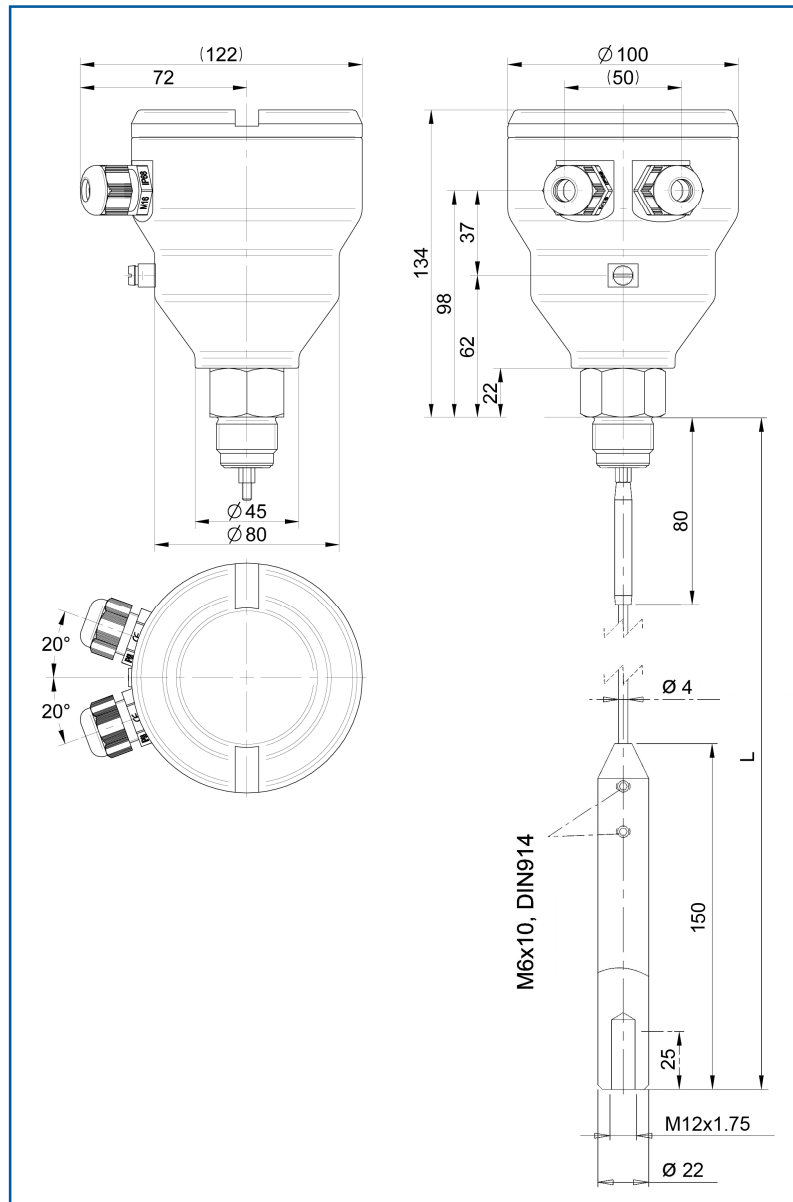

Fig. 5. Rope probe

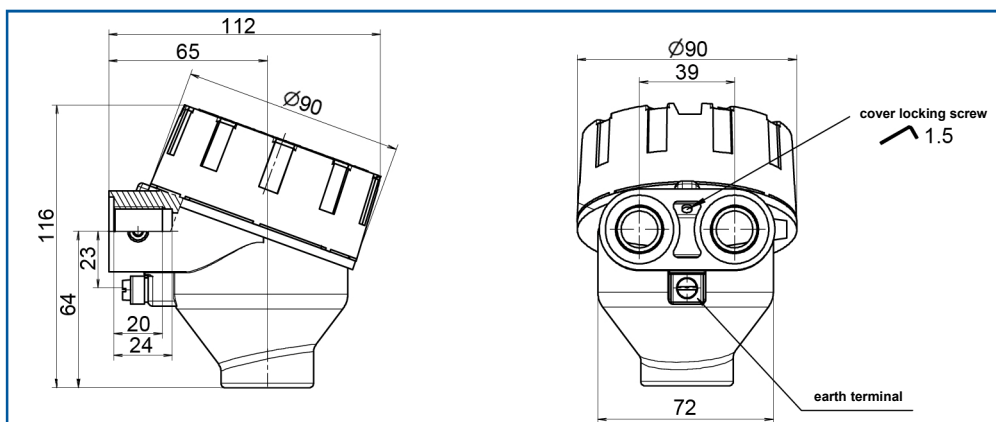

Fig. 6. ATEX housing

## ATEX version

The ATEX version of the LTDR is suitable for applications with hazardous gas or dust atmospheres, for applications requiring instruments of category 1/2G, 1/2D or 2G, 2D.

The installation of electrical equipment in hazardous areas must always be carried out by qualified personnel.

The approval certificate is in accordance to:

**CE** 0158 SEV 09 ATEX 0171 X

and the different markings are:

- II 1/2G Ex ia/d IIC T6
- II 1/2D Ex iaD/tD A20/21 IP68 T86°C
- II 2G Ex ia d IIC T6
- II 2D Ex iaD tD A21 IP68 T86°C
- II 1/2G Ex ia/d IIC T6 Ga/Gb
- II 1/2D Ex ia/t IIC T86°C Da/Db
- II 2G Ex ia d IIC T6 Gb
- II 2D Ex ia t IIC T86°C Db

## Electrical data

- Power supply (terminals 1 and 2):  $U = 12 \dots 30 \text{ VDC}$   
 $U_m = 250 \text{ VAC}$
- Analog output (terminals 3 and 4):  $I = 4\text{-}20\text{mA}$   
 $U_m = 250 \text{ VAC}$
- Switch output (terminals 5 and 6):  $U_s = 0 \dots U$   
 $U_m = 250 \text{ VAC}$

## Temperatures

Temperature class	Application temperature	Ambient temperature
<b>CATEGORY 1/2G</b>		
T1 ... T6	-20 ... +60°C	-40 ... +70°C
<b>CATEGORY 2G</b>		
T6	-40 ... +85°C	
T5	-40 ... +100°C	-40 ... +70°C
T4	-40 ... +135°C	
T1 ... T3	-40 ... +150°C	
<b>CATEGORY 1/2D &amp; 2D</b>		
Max. temperature: +86°C		-40 ... +70°C

## Configuration

Basic configuration of LTDR can be done directly on the device via a DIP switch, a single push button and visual feedback from a LED (fig. 7).

All settings required to get LTDR fully operational can be performed directly on the device. The LTDR can also be ordered completely pre-configured.

For greater convenience, remote configuration, and extensive diagnostics, a simple spread sheet can be provided through which the configuration can be done.

A standard HART™ modem is required for communication between computer and sensor. Communication is done via a digital HART™ signal that is superimposed onto the analog 4-20 mA signal of the current output.

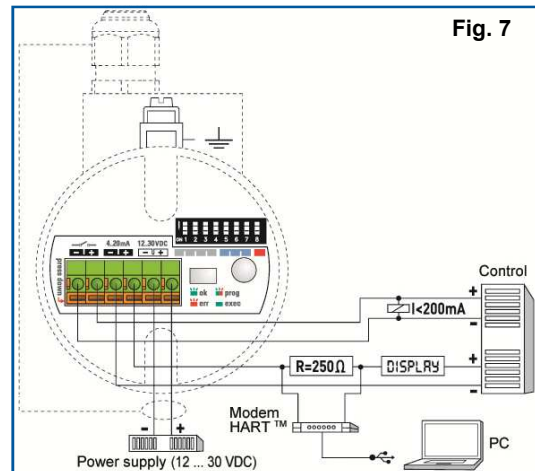

## Mounting

LTDR is mounted vertically to the tank via its connection thread, which is screwed directly into a standard threaded tank connection, i.e. weld in socket, or it can be screwed into a flange, which is then connected to a tank nozzle (fig. 8).

The customer has to ensure proper temperature and pressure ratings for his application and has to select the appropriate seal to connect the sensor (LTDR standard seal material is Klingersil® C-4400 for G<sup>3</sup>/<sub>4</sub>A connection thread).

LTDR is well suited for side mounting into a tank (fig. 9). In addition, LTDR is also the ideal combination with TECFLUID LT type level series in order to have a local indication of the level and an associated transmitter. In these cases the recommended probe type is the rod probe. The chamber acts as an external tube of a coaxial probe (fig. 10).

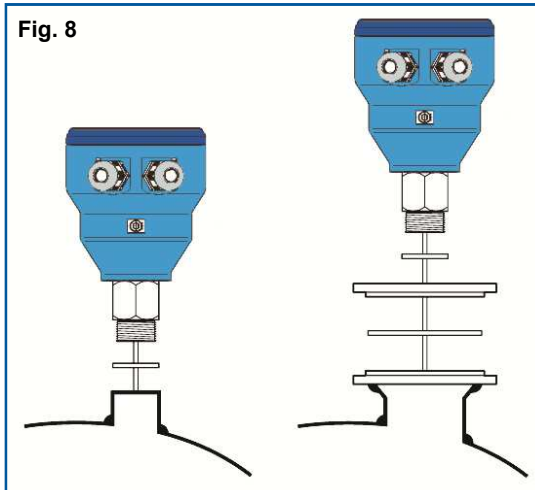

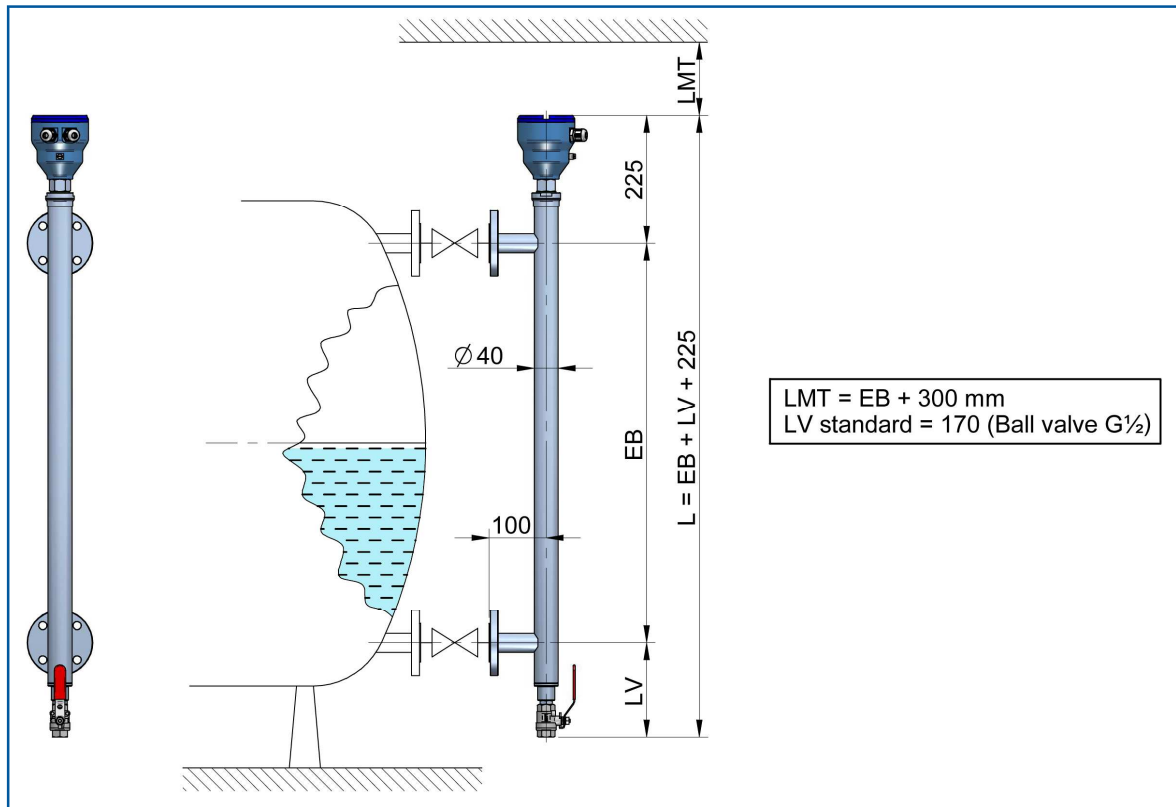

Fig. 9. Side mounting

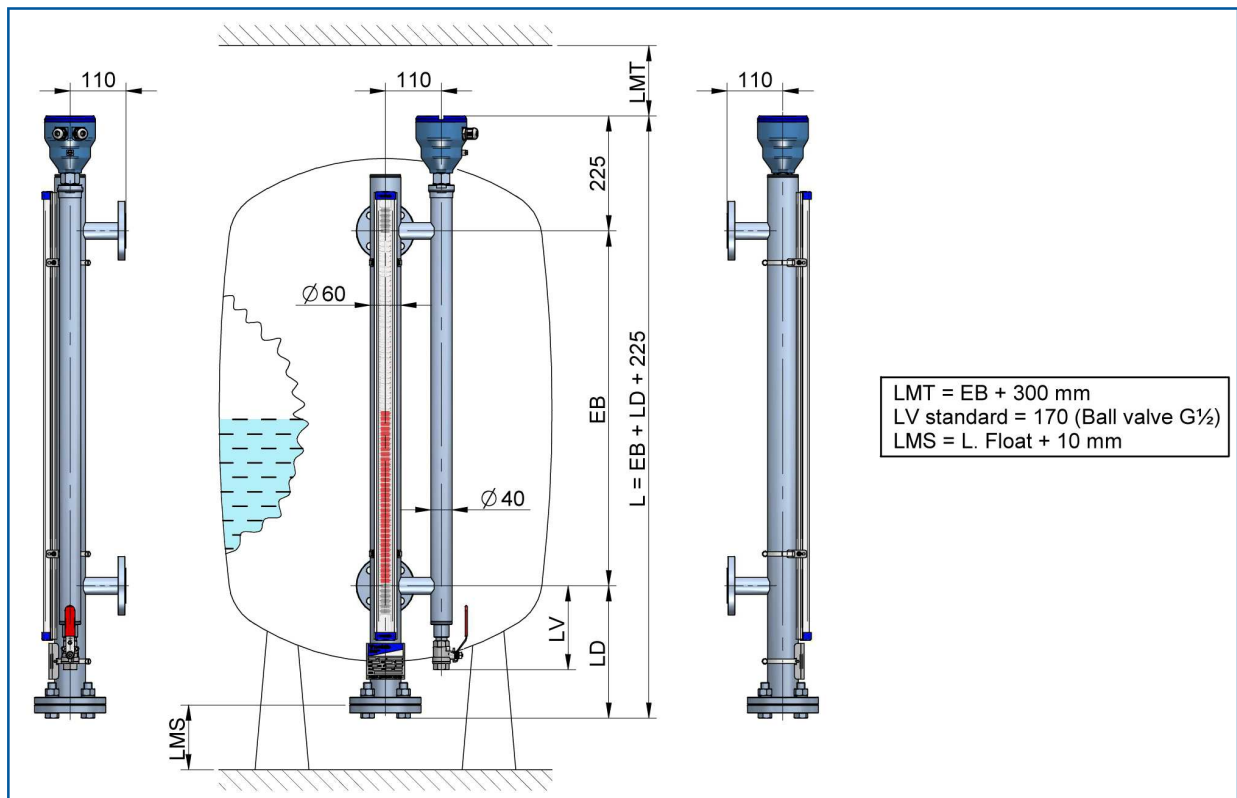

Fig. 10. LTDR in combination with LT type level gauge



**...presence in more than 50 countries around the world**

Quality Assurance System ISO 9001 certified by **Applus<sup>®</sup>**  
Pressure Equipment Directive 97/23/CE certified by **Lloyds Register**  
ATEX Directive 94/9/CE certified by **LDM**

**TECFLUID**

TECFLUID, S.A. design and manufacture instrumentation for flow and level measurement using the most advanced techniques.  
May you need more information, please contact us.

Narcís Monturiol 33 - 08960 Sant Just Desvern (Barcelona)  
Tel.: (+34) 93 3724511 - Fax: 93 4730854 - Fax intl.: +34 93 4734449  
[www.tecfluid.com](http://www.tecfluid.com) - e-mail: [tecfluid@tecfluid.com](mailto:tecfluid@tecfluid.com)

The technical data described in this specification sheet is subject to modification without notification if the technical innovations in the manufacturing processes so require.