

Electromagnetic flowmeters

Series FLOMID



Electromagnetic flowmeter for conductive liquids

- Flow rate measurement is independent of density, temperature, viscosity and pressure
- Pulsed coil excitation to obtain a minimum zero drift
- No moving parts involve low maintenance, low pressure drop and allows the pass of solids
- Can be mounted in any position (full pipe required)
- Can be installed with short straight pipe sections of minimum 5 x DN before and 3 x DN after the flowmeter
- Good chemical resistance
- Flow rate: 10 l/h ... 14100 m³/h
- Accuracy: $\pm 0.5\%$ reading value
- Minimum electric conductivity: 20 $\mu\text{S}/\text{cm}$
- Connections:
 - Between EN 1092-1 or ANSI flanges: DN3 ... DN150
 - EN 1092-1 or ANSI flanges: DN10 ... DN1000
 - Sanitary connections: DN10 ... DN100
According to ISO 2852, SMS 1145, DIN 11851, TRI-CLAMP®
- Other standards on request
- Materials:
 - Lining in PP, PVDF, PTFE and Ebonite (hard rubber)
 - Electrodes in Hastelloy C22 (UNS-06022), Titanium, EN 1.4404 (AISI 316L), Tantalum, Zirconium
 - Flow tube in EN 1.4301 (AISI 304)
- Local indication, volume totalizer, 4-20 mA and pulse outputs
- Alarms, empty pipe detection, etc. depending on converter model
- Full diagnosis for MX4 converter
- HART and Modbus Communication protocols available on request
- Modular design in two versions:
 - Compact converter, mounted on top of the sensor
 - Remote converter for wall or pipe mounting



The measurement principle is based on Faraday's induction law. A voltage V is induced between a pair of electrodes when a conductive liquid flows in a pipe of diameter D at an average velocity v_m , through a magnetic field B (which is perpendicular to the flow direction).

This voltage, proportional to the average velocity of the liquid, is acquired by the electronic converter in order to be processed and converted to a flow rate measurement.

$$V = B \cdot v_m \cdot D$$

V = Voltage across the electrodes

v_m = Liquid velocity

B = Magnetic field strength

D = Pipe diameter

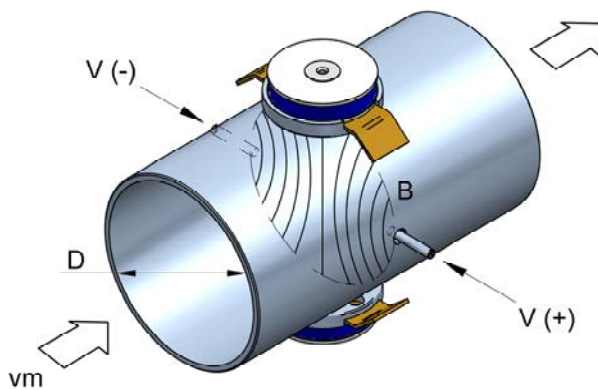

Applications

- Cooling-heating circuits & water treatment plants
- Food and beverage and pharmaceutical industries
- Petrochemical industry and offshore platforms
- Paper industry and fertilizer plants
- Car industry and machinery testing

Technical data

- **Accuracy:** $\pm 0.5\%$ reading value for flow speed ≥ 0.4 m/s
- **Minimum electric conductivity:** 20 $\mu\text{S}/\text{cm}$
- **Connections:**
 - Between EN 1092-1 or ANSI flanges: DN3 ... DN150
 - EN 1092-1 or ANSI flanges: DN10 ... DN1000
 - Sanitary connections: DN10 ... DN100, according to ISO 2852, SMS 1145, DIN 11851, TRI-CLAMP®
- Other standards on request
- **Materials:**
 - Lining in PP, PVDF, PTFE and Ebonite (hard rubber)
 - Electrodes in Hastelloy C22 (UNS-06022), Titanium, EN 1.4404 (AISI 316L), Tantalum, Zirconium
 - Flow tube in EN 1.4301 (AISI 304)
- **Local indication, volume totalizer, 4-20 mA and pulse outputs**

- **Full diagnosis** for MX4 converter
- **HART (MX4H & XT5H converters) and Modbus (MX4B converter) communication protocols** available on request
- **Modular design** in two versions:
 - Compact converter (MX4 or XT5), mounted on top of the sensor
 - Remote converter (MX4M or XT5M) for wall or pipe mounting

Installation

For the mechanical installation the most important factor to be taken into consideration is that the pipe must always be full and the electrodes in contact with the liquid.

To guarantee this, the sensor should be mounted with the electrodes in a horizontal line and in a place of the installation so that the liquid does not contain air pockets.

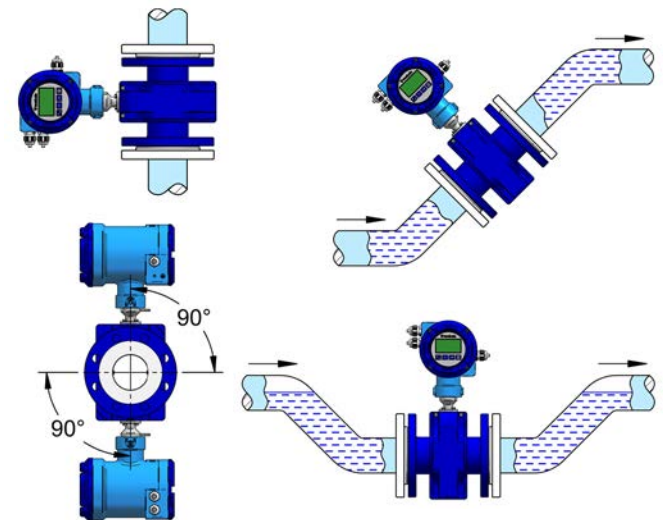

Vibration

Fasten the pipe at both sides of the sensor, mainly in cases with free runs of piping over 10 m long, in which mechanical supports are recommended to minimize external forces.

Caution: in plants with excessive vibration, it is recommended to install the electronic converter separate from the sensor.

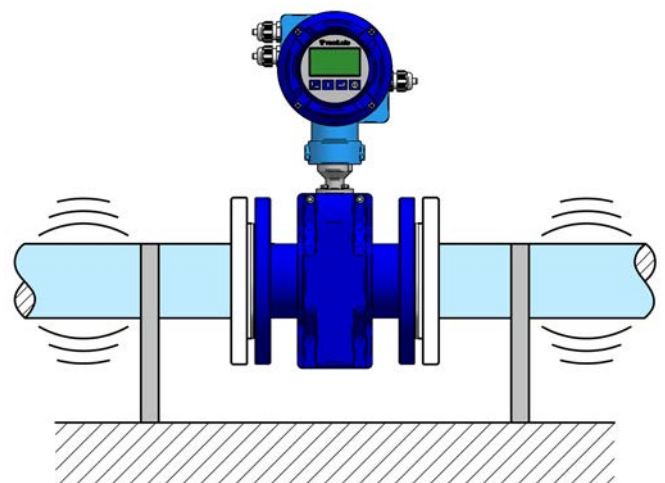

Electromagnetic flowmeters

Straight sections of pipe are necessary for the proper operation of the flowmeter. Required straight pipe run depends on the flow profile, which can be affected by the disturbing elements found in the installation before and after the sensor. A minimum distance of at least 5 x DN upstream and 3 x DN downstream from the flowmeter must be kept.

Valves should be downstream from the flowmeter to keep the pipe full and to avoid vacuums which can damage the flowmeter liner.

Pumps should be upstream from the flowmeter to avoid vacuums.

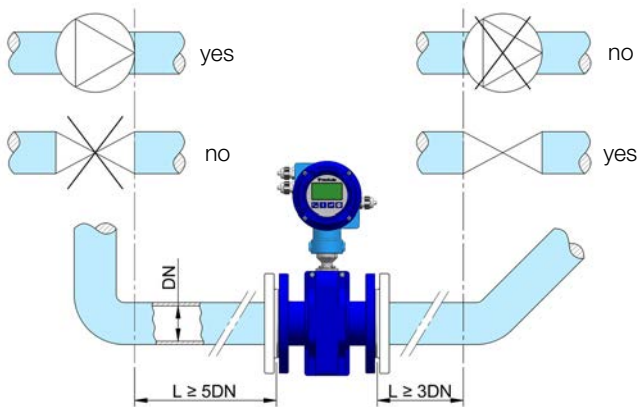

In case of mixtures of different liquids, the sensor should be installed a minimum of 30 x DN from the point of mixture to avoid instabilities in the readings.

Pressure loss when reducing the pipe diameter

In installations where, due to the low flow rate, it is necessary to reduce the pipe diameter, this should be done using a reduction cone with an angle of less than 4° in order to avoid turbulences which can give false readings.

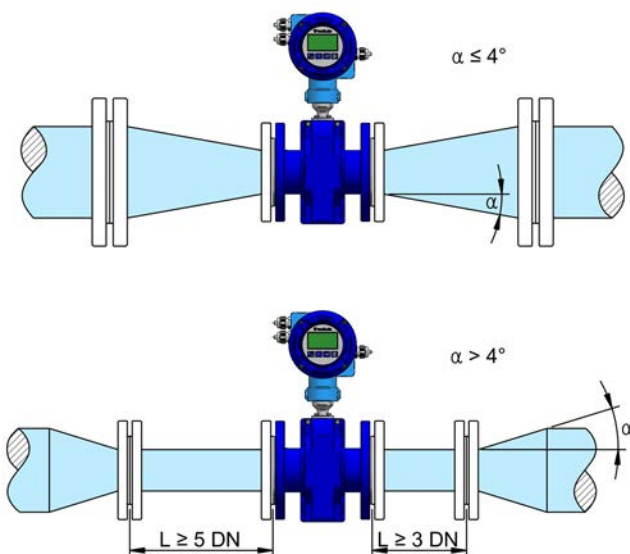

Earth connection

Series FLOMID

In order that the converter can acquire the signal from the electrodes, it has to be referenced to the same potential as the liquid. This can be considered as the most important factor for the correct working of the unit.

In the event that the pipe is made of electrically conductive material, just connect the two sensor wires to the pipe flanges, one to each side of the sensor.

If the inside of the pipe is plastic (or any other non-conductive material) two earthing rings and two more gaskets, one on each side of the sensor, must be installed. The earth wires will be connected to these earthing rings.

In case of liquids which are not compatible with metallic earthing rings, plastic rings with specific metallic electrodes are also available.

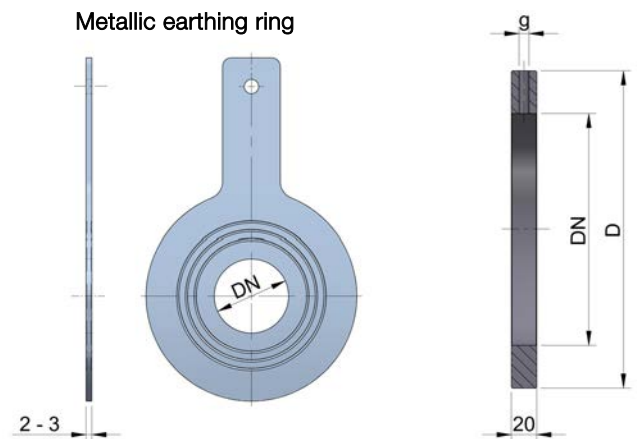

All dimensions in mm

Plastic earthing ring + electrode

Abrasive liquids or liquids containing solids

For abrasive liquids or liquids with particles in suspension, it is recommended to mount the flowmeter in a rising pipe. For a horizontal pipe the installation can be made as in the following drawing with a valve system for cleaning.

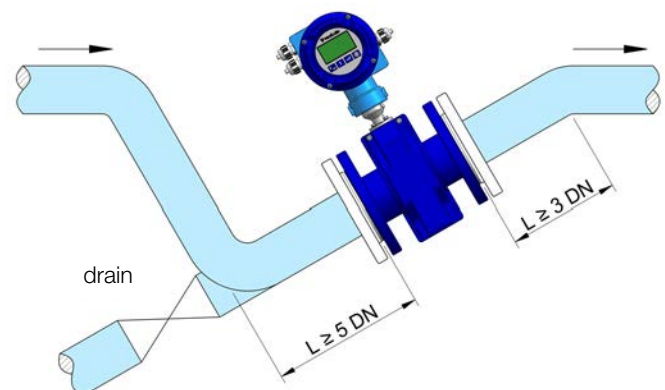

FLOMID-OFX (EN 1092-1 wafer mounted)

DN	PN (bar)	g	L	F	A	Ax	h	Weight (kg)
3		46	65	45	264	278	176	1.1
6		46	65	45	264	278	176	1.1
10		46	65	45	264	278	176	1.1
15		51	65	48	267	281	179	1.1
20		61	65	54	273	287	185	1.3
25	16	71	80	36	246	260	158	1.3
32		82	80	41	252	266	164	1.5
40		92	100	46	258	272	170	1.9
50		107	100	54	266	280	178	2.4
65		127	120	64	277	291	189	3.3
80		142	120	71	285	299	197	3.7
100		162	165	81	295	309	207	5.8
125	10	192	165	96	310	324	222	7.4
150		218	165	109	323	337	235	8.8

FLOMID-OFX (ANSI B16.5 wafer mounted)

DN	Class	g	L	F	A	Ax	h	Weight (kg)
1/8"		46	65	45	264	278	176	1.1
3/8"		46	65	45	264	278	176	1.1
1/2"		46	65	45	264	278	176	1.1
3/4"		55	65	48	267	281	179	1.3
1"		65	65	54	273	287	185	1.3
1 1/4"		74	80	37	246	260	158	1.5
1 1/2"	150#	84	80	42	252	266	164	1.9
2"		103	100	52	258	272	170	2.4
2 1/2"		122	100	61	266	280	178	3.3
3"		135	120	68	277	291	189	3.7
4"		173	165	87	295	309	207	5.8
5"		192	165	96	310	324	222	7.4
6"		218	165	109	323	337	235	8.8

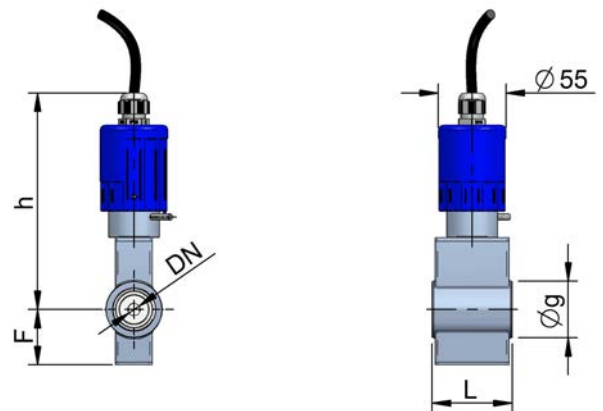
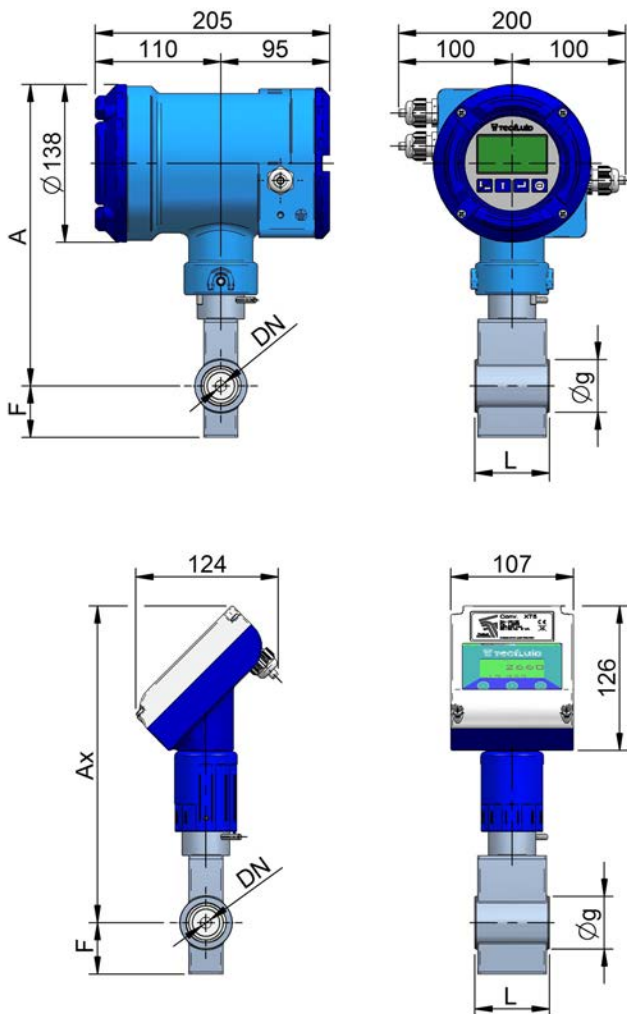

FLOMID-OFX with compact MX4 converter

(All dimensions in mm)

Electromagnetic flowmeters

Series FLOMID

FLOMID sensor flanged mounted, common dimensions

DN	ANSI	PN (Class)	L1	L2	A	Ax	h	Weight (kg)
10	3/8"		85	150	290	304	202	3.0
15	1/2"		85	150	290	304	202	3.0
20	3/4"		85	150	290	304	202	3.4
25	1"		85	150	290	304	202	4.3
32	1 1/4"		85	150	297	311	209	5.3
40	1 1/2"	16	85	150	297	311	209	5.8
50	2"	(150#)	90	200	324	338	236	7.7
65	2 1/2"		90	200	324	338	236	9.3
80	3"		90	200	324	338	236	10.7
100	4"		110	250	318	332	230	15.0
125	5"		110	250	330	344	242	17.0
150	6"		110	300	344	358	256	19.0
200	8"		110	350	370	384	282	31.0
250	10"		110	400	396	410	308	45.0
300	12"		110	500	418	432	330	52.0
350	14"	10	110	500	444	458	356	62.0
400	16"	(150#)	110	600	469	483	381	76.0
450	18"		300	600	525	539	437	85.0
500	20"		300	600	552	566	464	98.0

FLOMID-2FX (EN 1092-1 flanged mounted)

DN	PN	D	K	l x n°	g	F
10		90	60	14 x 4	40	71
15		95	65	14 x 4	45	71
20		105	75	14 x 4	58	71
25		115	85	14 x 4	68	71
32		140	100	18 x 4	78	78
40	16	150	110	18 x 4	88	78
50		165	125	18 x 4	102	105
65		185	145	18 x 8	122	105
80		200	160	18 x 8	138	105
100		220	180	18 x 8	158	110
125		250	210	18 x 8	188	125
150		285	240	22 x 8	212	143
200		340	295	22 x 8	268	170
250		395	350	22 x 12	320	198
300		445	400	22 x 12	370	223
350	10	505	460	22 x 16	430	253
400		565	515	26 x 16	482	383
450		615	565	26 x 20	532	309
500		670	620	26 x 20	585	336

FLOMID-4FX (ANSI flanged mounted)

ANSI	Class	D	K	l x n°	g	F
3/8"		88.9	60.3	15.7 x 4	34.9	71
1/2"		88.9	60.3	15.7 x 4	34.9	71
3/4"		98.4	69.8	15.7 x 4	42.9	71
1"		107.9	79.4	15.7 x 4	50.8	71
1 1/4"		117.5	88.9	15.7 x 4	63.5	78
1 1/2"		127.0	98.4	15.7 x 4	73.0	78
2"		152.4	120.6	19.1 x 4	92.1	105
2 1/2"		177.8	139.7	19.1 x 4	104.8	105
3"		190.5	152.4	19.1 x 4	127.0	105
4"	150#	228.6	190.5	19.1 x 8	157.2	115
5"		254.0	215.9	22.4 x 8	185.7	127
6"		279.4	241.3	22.4 x 8	215.9	140
8"		342.9	298.4	22.4 x 8	269.9	172
10"		406.4	361.9	25.4 x 12	323.8	203
12"		482.6	431.8	25.4 x 12	381.0	242
14"		533.4	476.2	28.4 x 12	412.7	267
16"		596.9	539.7	28.4 x 16	469.9	298
18"		635.0	577.8	31.8 x 16	533.4	318
20"		698.5	635.0	31.8 x 20	584.2	349

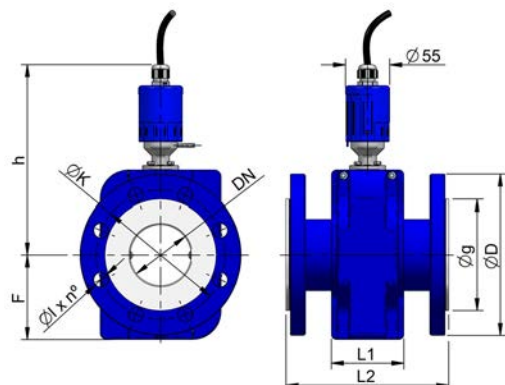
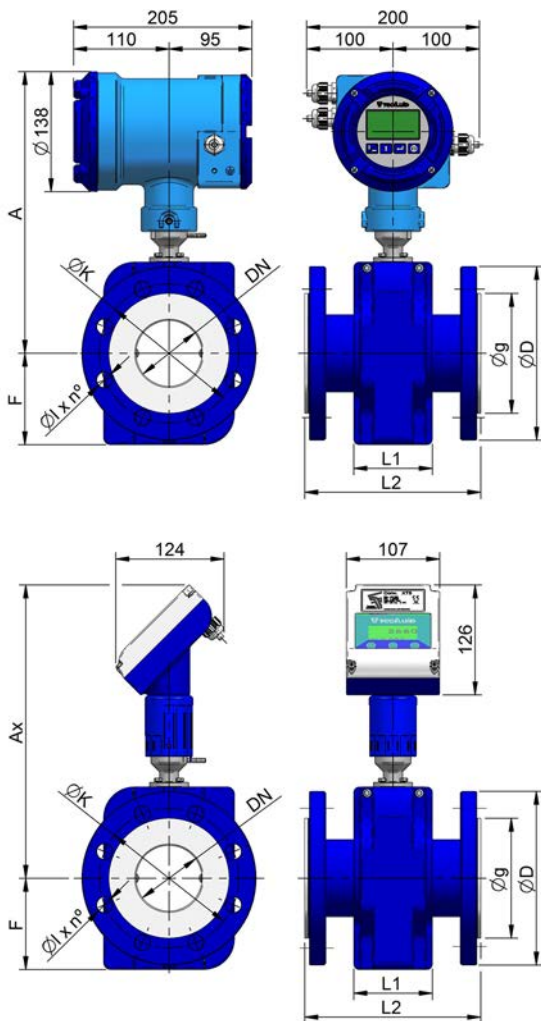

(All dimensions in mm)

Electromagnetic flowmeters with fully hygienic execution

Sensor with PTFE lining and AISI 316L end connectors, suitable for hygienic applications in pharmaceutical and food and beverage industries, among others. Available with MX4 and XT5 converters.

Dimensions

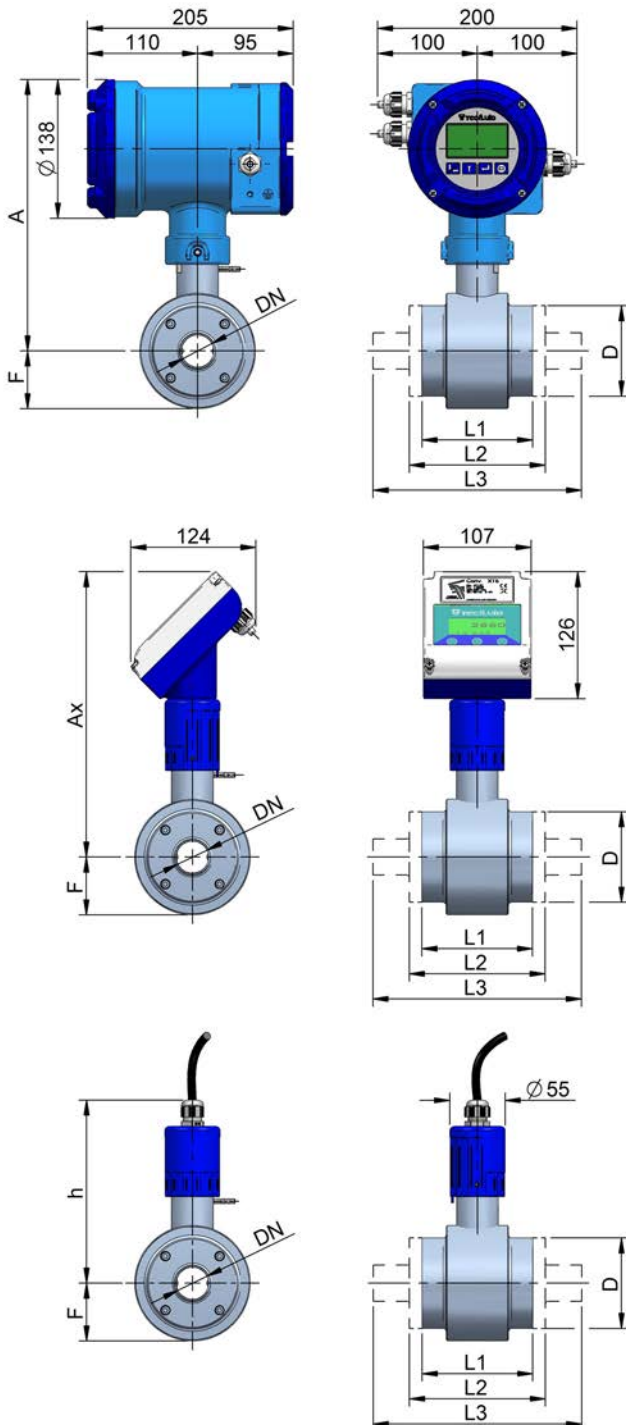

(All dimensions in mm)

DN	L1	L2	D	A	Ax	h	F
10	104	120	60	260	274	172	48
15	104	120	65	260	274	172	48
20	104	120	70	262	276	174	50
25	110	134	80	262	276	174	50
32	110	134	90	270	284	182	58
40	130	154	100	270	284	182	58
50	130	154	115	279	293	191	66
65	160	186	145	292	306	204	79
80	160	186	160	300	314	212	86
100	204	234	180	316	330	228	102

FLOMID-1FX (DIN 11851)

DN	di	R	D	L1	L2	L3	H
10	10	Rd 28 x 1/8"	60	104	120	200	48
15	16	Rd 34 x 1/8"	65	104	120	200	48
20	20	Rd 44 x 1/6"	70	104	120	200	48
25	26	Rd 52 x 1/6"	80	110	134	220	55
32	32	Rd 58 x 1/6"	90	110	134	220	55
40	38	Rd 65 x 1/6"	100	130	154	240	55
50	50	Rd 78 x 1/6"	115	130	154	240	55
65	66	Rd 95 x 1/6"	145	160	186	280	60
80	81	Rd 110 x 1/4"	160	160	186	280	60
100	100	Rd 130 x 1/4"	180	204	234	330	63

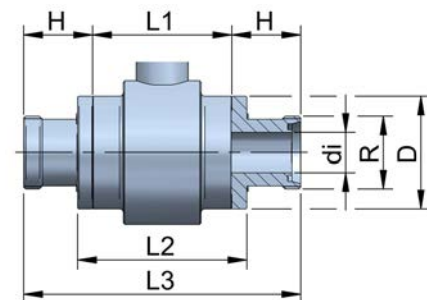

FLOMID-3FX (SMS 1145)

DN	di	R	D	L1	L2	L3	H
25	22.5	Rd 40 x 1/6"	80	110	134	220	55
32	29.5	Rd 48 x 1/6"	90	110	134	220	55
40	35.5	Rd 60 x 1/6"	100	130	154	240	55
50	48.5	Rd 70 x 1/6"	115	130	154	240	55
65	60.5	Rd 85 x 1/6"	145	160	186	280	60
80	72.0	Rd 98 x 1/6"	160	160	186	280	60

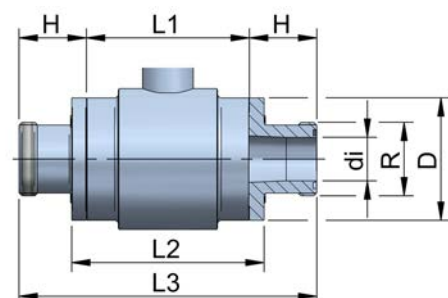

Electromagnetic flowmeters

FLOMID-5IFX (CLAMP ISO 2852)

DN	OD*	di	C	D	L1	L2	L3	H
10	12.0	10.0	34.0	60	104	120	200	48
10	12.7	10.7	34.0	60	104	120	200	48
15	17.2	15.2	34.0	65	104	120	200	48
20	21.3	19.3	34.0	70	104	120	200	48
25	25.0	22.6	50.5	80	110	134	220	55
32	33.7	31.3	50.5	90	110	134	220	55
40	38.6	35.6	50.5	100	130	154	240	55
50	51.0	48.6	64.0	115	130	154	240	55
65	63.5	60.3	77.5	145	160	186	280	60
80	76.1	72.9	91.0	160	160	186	280	60
100	101.6	97.6	119.0	180	204	234	330	63

* OD = pipe outer Ø according to ISO 2037

FLOMID-5TFX (TRI-CLAMP®)

DN	Coup.	OD*	di	C	D	L1	L2	L3	H
10	½"	12.7	9.4	25.0	60	104	120	200	48
15	¾"	19.0	15.7	25.0	65	104	120	200	48
25	1"	25.4	22.1	50.4	80	110	134	220	55
40	1½"	38.1	34.8	50.4	100	130	154	240	55
50	2"	50.8	47.5	63.9	115	130	154	240	55
65	2½"	63.5	60.2	77.4	145	160	186	280	60
80	3"	76.2	72.9	90.9	160	160	186	280	60
100	4"	101.6	97.4	118.9	180	204	234	330	63

* OD = pipe outer Ø according to ASME BPE DT-1

FLOMID-7FX (ISO 2853)

DN	di	R	C	D	L1	L2	L3	H
10	10.0	Tr 22.89 x 1/8"	15.0	60	104	120	200	48
15	15.2	Tr 29.26 x 1/8"	21.2	65	104	120	200	48
20	19.3	Tr 33.53 x 1/8"	25.4	70	104	120	200	48
25	22.6	Tr 37.13 x 1/8"	29.0	80	110	134	220	55
32	31.3	Tr 45.97 x 1/8"	38.0	90	110	134	220	55
40	35.6	Tr 50.65 x 1/8"	42.5	100	130	154	240	55
50	48.6	Tr 64.16 x 1/8"	56.0	115	130	154	240	55
65	60.3	Tr 77.67 x 1/8"	69.7	145	160	186	280	60
80	72.9	Tr 91.19 x 1/8"	82.3	160	160	186	280	60
100	97.6	Tr 118.21 x 1/8"	108.5	180	204	234	330	63

FLOMID-9WDFX (DIN 11850 weld-on connections)

DN	de*	di	D	L1	L2	L3	H
10	13	10	60	104	120	180	38
15	19	16	65	104	120	180	38
20	23	20	70	104	120	180	38
25	29	26	80	110	134	190	40
32	35	32	90	110	134	190	40
40	41	38	100	130	154	210	40
50	53	50	115	130	154	210	40
65	70	66	145	160	186	250	45
80	85	81	160	160	186	250	45
100	104	100	180	204	234	300	48

Also available FLOMID-9WIFX (ISO 2037 weld-on connections)

Also available FLOMID-6BFX (BSP connection) and FLOMID-6NFX (NPT connection)

FLOMID-5DFX (CLAMP DIN 32676) **Series FLOMID**

DN	OD*	di	C	D	L1	L2	L3	H
10	13	10	34.0	60	104	120	200	48
15	19	16	34.0	65	104	120	200	48
20	23	20	34.0	70	104	120	200	48
25	29	26	50.5	80	110	134	220	55
32	35	32	50.5	90	110	134	220	55
40	41	38	50.5	100	130	154	240	55
50	53	50	64.0	115	130	154	240	55
65	70	66	91.0	145	160	186	280	60
80	85	81	106.0	160	160	186	280	60
100	104	100	119.0	180	204	234	330	63

* OD = pipe outer Ø according to DIN 11850 (Series 2)

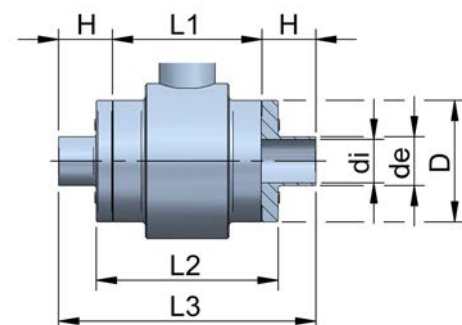
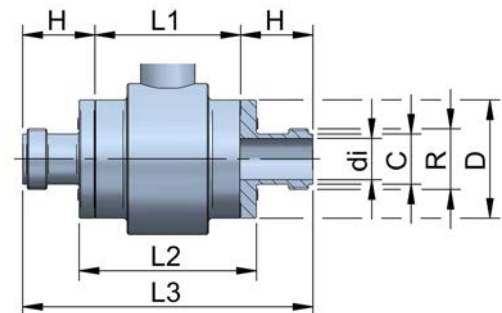
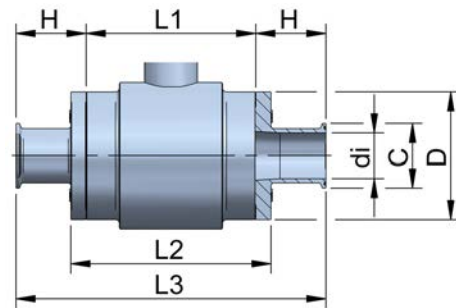

Sensor selection

The diagram shows the correspondance between the liquid velocity and the flow rate for different sensor sizes.

The sensor size should be chosen selecting a liquid velocity of about 3-4 m/s. The minimum liquid velocity should not be below 0.5 m/s.

When the liquid has solids in suspension, it is better to work between 3 and 5 m/s in order to avoid sedimentation in the pipe and sensor.

Accuracy curve (error vs velocity)

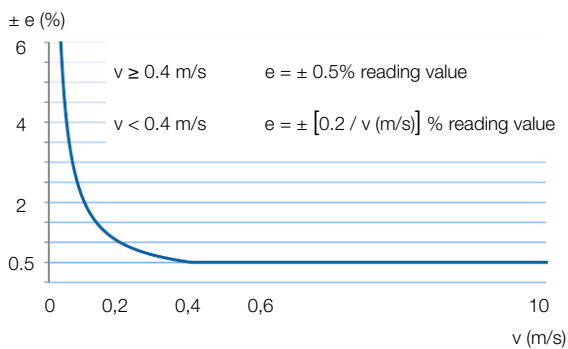

FLOMID-2FX with compact XT5 converter

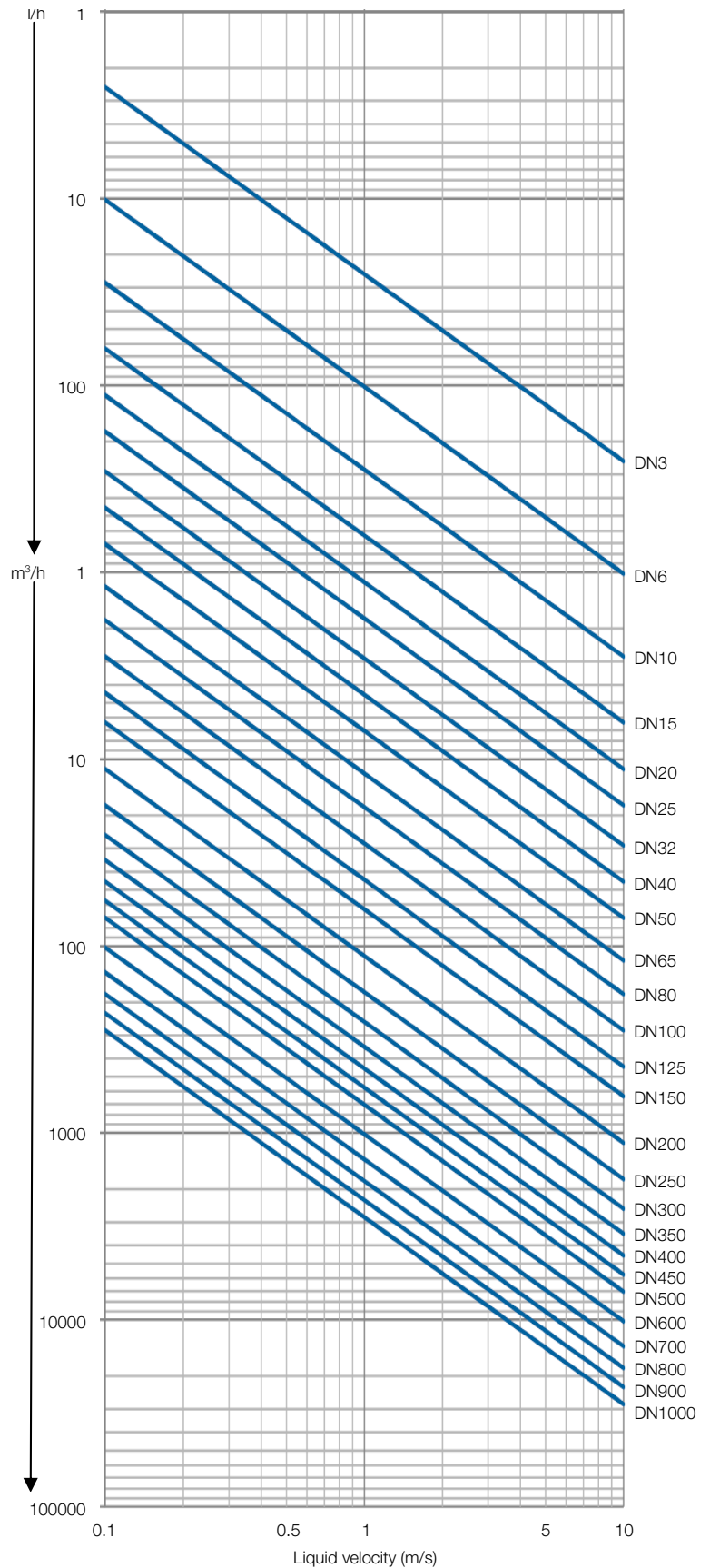

Electromagnetic flowmeters

Series FLOMID

DN	PTFE FLOMID-2FX / 4FX		PVDF / PTFE FLOMID-0FX / Sanitary		PP FLOMID-0FX		EBONITE (hard rubber) FLOMID-2FX / 4FX		DN
	PN (Class)	Vacuum ⁽¹⁾	PN (Class)	Vacuum ⁽¹⁾	PN (Class)	Vacuum ⁽¹⁾	PN (Class)	Vacuum ⁽¹⁾	
3									3
6									6
10				60 / 500		100 / 600			10
15									15
20									20
25		80 / 500	PN16 (150#)		PN16 (150#)				25
32				100 / 600		180 / 700			32
40	PN16 (150#)							100 / 200	40
50									50
65		150 / 650		150 / 700		200 / 800	PN16 (150#)	120 / 250	65
80									80
100		250 / 750	PN10 (150#)	300 / 800	PN10 (150#)	380 / 900		280 / 400	100
125		450 / 800		480 / 900		650 / 1000			125
150									150
200		450 / 900							200
250		500 / 1000						300 / 450	250
300									300
350									350
400	PN10 (150#)	750 / 1000					PN10 (150#)	500 / 600	400
500									500
600									600
700									700
800		1000 / 1000						1000 / 1000	800
900									900
1000									1000
Temp. range	-20°C ... +120°C		-20°C ... +120°C		-10°C ... +80°C		-20°C ... +90°C		Temp. range
Limit ⁽²⁾	130°C		130°C		-		-		Limit ⁽²⁾

⁽¹⁾ In mbar absolute, 40°C / 80°C reference temperature

⁽²⁾ Maximum 30'



FLOMID-0FX with compact XT5 converter



FLOMID-0FX with remote XT5M converter

Electronic converters

Different models of electronic control units are available to comply with the options of flow indication, maximum / minimum flow rate control, analog and pulse outputs.

All of them are compatible with the different FLOMID-FX sensor models.

These converters can be supplied for compact mounting directly on top of the sensor or for remote mounting. Cable is supplied.

HART protocol is available for both MX4 and XT5 converters.

Modbus RTU protocol is available for MX4 converter.

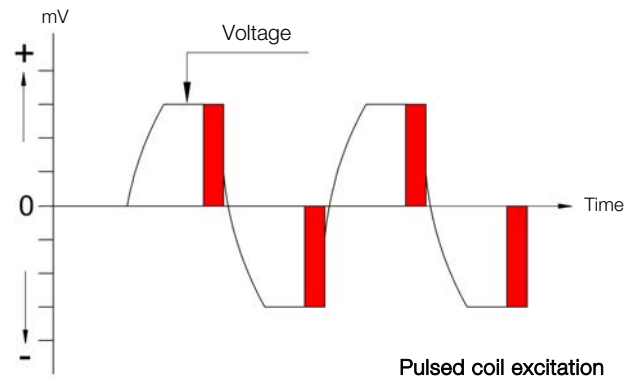

XT5 converter



Technical data

- IP67 polycarbonate enclosure
- Programming via front tactile push buttons
- Linearity: $\pm 0.2\%$ f.s.
- Repeatability: $\pm 0.1\%$ f.s.
- Ambient temperature range: $0^{\circ}\text{C} \dots +60^{\circ}\text{C}$
- Power supply: 24, 115, 230, 240 VAC 50 / 60 Hz
24 VDC
- Power consumption: ≤ 5 VA
- Flow rate indication:
 - No. of digits: 4 (0 to 2 decimal configuration)
 - Digit size: 5 mm
- Volume totalizer:
 - No. of digits: 7 (2 decimal)
 - Digit size: 8 mm
 - Reset button
- Analog output: 4-20 mA, active or passive, programmable measuring units
- Pulse output: optoisolated:
 - V_{max} : 30 VDC ; I_{max} : 30 mA
 - Maximum frequency in "P/U" mode: 6.25 Hz
 - Frequency in "Hz" mode: 0.04 ... 5000 Hz
- Empty pipe detection
- Flow rate cut off, programmable
- Adaptive flow rate filter: programmable integration time between 0.1 ... 20 seconds
- Zero offset adjustment

Remote mounted converter (model XT5M)

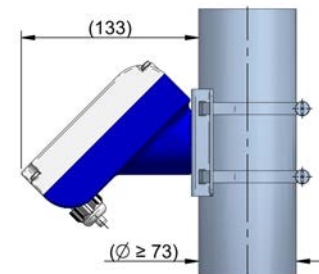
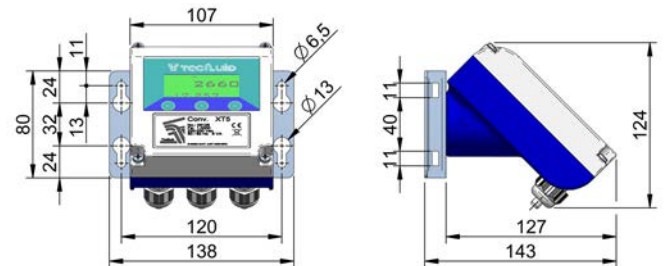

Weight XT5: 700 g

XT5 compact converter



XT5M remote converter



HART Communication protocol

XT5H converter has a modem for HART communication. All the features regarding HART communication can be found in the corresponding document "Field Device Specification". Compatible with HART Server Communication software.

Also available for remote mounted version XT5HM.

MX4 converter

Technical data

- IP67 coated aluminium enclosure • Programming via front push buttons
- 128 x 64 graphic display
- Linearity: $\pm 0.2\%$ f.s.
- Repeatability: $\pm 0.1\%$ f.s.
- Ambient temperature range: $-20^{\circ}\text{C} \dots +60^{\circ}\text{C}$
- Power supply: 90 ... 265 VAC 50 / 60 Hz
12 ... 48 VDC • Power consumption: ≤ 5 VA
- Flow rate and liquid velocity indication:
 - No. of digits: 5 (0 to 2 decimal configuration)
 - Digit size: 11 mm
- Volume totalizer:
 - No. of digits: 8 (2 decimal)
 - Digit size: 8 mm
 - Reset button
- Analog output: 4-20 mA, active or passive, programmable measuring units
- Pulse output: optoisolated NPN bipolar transistor:
 - V_{max} : 30 VDC ; I_{max} : 30 mA
 - Output frequency: 0.01 ... 5000 Hz
 - Programmable duty cycle
- Relay outputs: 2 relays with potential free contacts.
 - Contact characteristics:
 - Maximum voltage: 250 VAC
 - Maximum current: 8 A
 - Maximum power: 500 VA

Programmable as flow rate alarms, empty pipe detection or reversed flow indication

- Empty pipe detection
- Flow rate cut off, programmable
- Adaptive flow rate filter: programmable integration time between 0 ... 40 seconds
- Zero offset adjustment
- Full diagnosis of the coil current, the differential voltage on the sensor electrodes and the conductivity of the liquid, as well as detection of an electronic failure in the measuring circuit
- Easy programmable by means of Tecfluid's Winsmeter MX4 software, available for download at www.tecfluid.com

HART and Modbus RTU RS485 Communication protocols

MX4B converter includes a Modbus RTU

RS485

Communication protocol module.

MX4H converter has a modem for HART communication. All the features regarding HART communication can be found in the corresponding document "Field Device Specification". Compatible with HART Server Communication software.



Remote mounted converter (model MX4M)

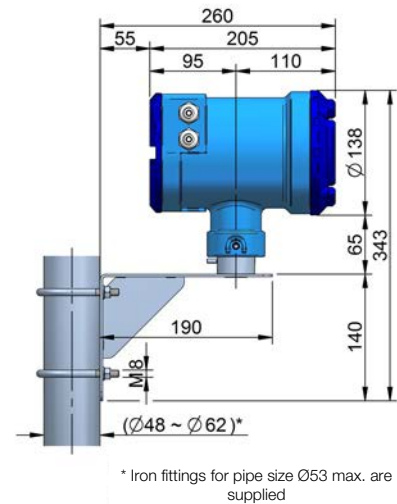
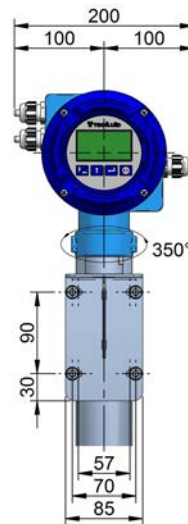
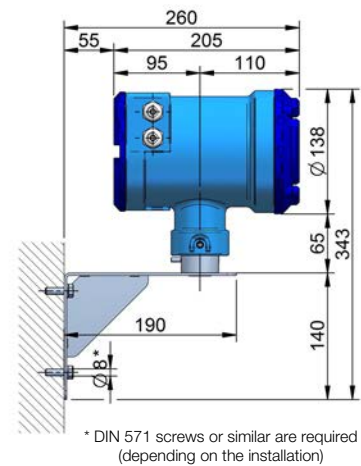
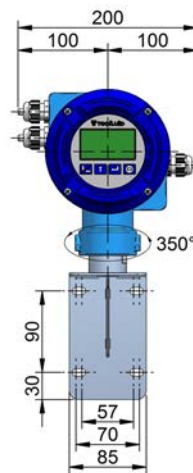

Weight MX4: 3.3 kg



FLOMID-2FX with compact MX4 converter

