

Tuvalet Çalparası-Fırtına Vanası (Düz Tip) / Storm Valve (Straight Type)

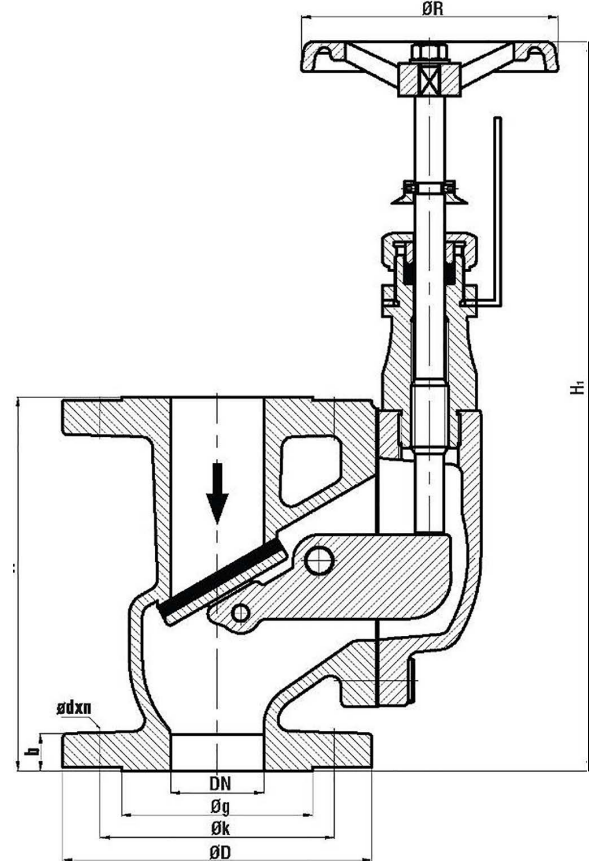

| NO | PARÇA ADI | PART NAME | MATERIAL | NO | PARÇA ADI | PART NAME | MATERIAL |
|----|-----------------|------------------|-----------|----|----------------|----------------|-----------|
| 1 | GÖVDE | BODY | GGG40.3 | 11 | ÜST KAPAK | LOCKING DIVECE | CuZn39Pb3 |
| 2 | KLAPE | DISC | RG5 | 12 | GÖSTERGE | INDICATOR | AISI 304 |
| 3 | CONTA | GASKET | NBR | 13 | SOMUN | NUT | CuZn39Pb3 |
| 4 | KLAPE AĞIRLIK | DISC WEIGHT | GGG40.3 | 14 | SALMASTRA | PACKING | GRAPHITE |
| 5 | PİM & KOPİLYA | PIN & KOTTER PIN | CuZn39Pb3 | 15 | BASKI RİNGİ | PRESS RING | CuZn39Pb3 |
| 6 | MERKEZLEME PİMİ | CENTER PIN | CuZn39Pb3 | 16 | BASKI SOMUNU | PRESS NUT | CuZn39Pb3 |
| 7 | CONTA | GASKET | KLINGERIT | 17 | GÖSTERGE KOLU | INDICATOR ARM | AISI 304 |
| 8 | KAPAK | BONNET | GGG40.3 | 18 | SETSKUR CİVATA | GRUB SCREW | 8.8 STEEL |
| 9 | CİVATA | BOLT | 8.8 STEEL | 19 | HENDİL | HANDWHEEL | GG25 |
| 10 | MİL | STEM | AISI 420 | 20 | SOMUN & PUL | NUT & WASHER | STEEL |

| DN | ØD | Øg | Øk | b | H | H ₁ | ØR | Ødxn | STROK | KG |
|-----|-----|-----|-----|----|-----|----------------|-----|------|-------|------|
| 50 | 165 | 102 | 125 | 20 | 200 | 320 | 160 | 18x4 | 40 | 17,5 |
| 65 | 185 | 122 | 145 | 20 | 240 | 360 | 160 | 18x4 | 40 | 22 |
| 80 | 200 | 138 | 160 | 20 | 260 | 380 | 160 | 18x8 | 50 | 27 |
| 100 | 220 | 158 | 180 | 22 | 300 | 430 | 200 | 18x8 | 50 | 38 |
| 125 | 250 | 188 | 210 | 22 | 350 | 500 | 200 | 18x8 | 55 | 50 |
| 150 | 285 | 212 | 240 | 24 | 400 | 545 | 200 | 22x8 | 60 | 65 |

TEKNİK ÖZELLİKLER / TECHNICAL PROPERTY

DİZAYN/ DESIGN: DIN HNA SR6

BAĞLANTILAR / CONNECTIONS: FLANŞ EN1092-3/A (DIN 2501)/ FLANGES EN1092-3/A (DIN 2501)

ÇALIŞMA BASINCI / PRESSURE RATING: PN4 to PN10

ÇALIŞMA SICAKLIĞI/ WORKING TEMP. : -10°C ile 60°C / -10°C to 60°C

FLANŞ SEÇENEKLERİ/ FLANGE OPTIONS: ANSI veya JIS özel flanş yapılabilir/ Special flange drilling acc. to ANSI or JIS