

Explosion Proof General Purpose Solenoid Valve SX1020 Series (G1/8", G1/4",)

GENERAL FEATURES

- Wide pressure range, flow rate and orifis options.
- Solenoid valvs are used with filters.
- Solenoid valves can be mounted in any position without affecting its operation, coil to be used in a vertical position.
- It is applicable for natural gas, lpg, methan, butane, propane, gas, noncorrosive gas. These are applicable for valve usage
- Operating Temperature: -10 °C / +160 °C
- No pressure difference is required.

ELECTRICAL CHARACTERISTICS

Voltages Tolerance : AC -15%, +10% DC -5%, +10%
 Frequency : 50 Hz (60 Hz...)
 On request; Connector with LED, PWM Socket
 Specify coil voltage with order.

MATERIALS IN CONTACT WITH FLUID

Body : Brass
 Internal Parts : Stainless Steel, Brass
 Sealing : NBR on request ; EPDM, VITON
 Shading Ring : Copper (EN 12735-1)
 Seats, Core Tube, Springs: Stainless Steel

OPTIONS

- Female connection: BSP; (On request NPT)
- Manual use on request.
 - On request CR-Ni coating.
 - On request PTFE coating.
 - On request Atex (exproof) coil.

TECHNICAL FEATURES

Max. Viscosity : 5°E (-37cST veya mm²/s)
 Response Time : Opening time : 30 ms
 Closing Time : 30 ms

SEALS FEATURES

NBR : -10°C...+80°C
 EPDM : -10°C...+130°C
 VITON : -10°C...+160°C
 PTFE : -10°C...+160°C
 RUBY : -10°C...+160°C



NORMALLY CLOSED

2/2 WAY

DIRECT ACTING

ΔP=0



Dimensions (mm)							
G	A	B	C	D	E	F	H
1/8"	40	83	32	39	78	22,3	25,6
1/4"	40	83	32	39	78	22,3	25,6

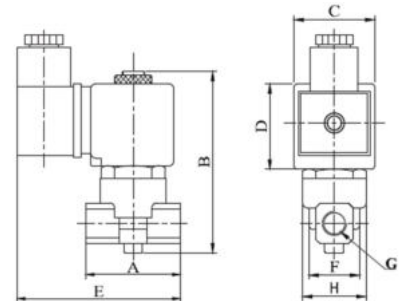

Coils	Nominal Values	Cold/ Hot	Inrush	Holding	Current (A)	Surface Temperature (°C)
C41012VDC18W	12VDC 18W	COLD	19,56	19,56	1,63	20
		HOT	14,52	14,52	1,21	106
C41024VDC18W	24VDC 18W	COLD	20,88	20,88	0,87	25
		HOT	14,64	14,64	0,61	116
C41110VDC18W	110VDC 18W	COLD	19,96	19,96	0,18	23
		HOT	13,56	13,56	0,123	115
C41012VAC15VA	12VAC 15VA	COLD	23,81	16,43	1,3	25
		HOT	-	15,86	1,262	79
C41024VAC15VA	24VAC 15VA	COLD	25,82	15,02	0,62	22
		HOT	-	13,91	0,57	81
C41110VAC15VA	110VAC 15VA	COLD	30,65	15,17	0,137	24
		HOT	-	13,96	0,126	80
C41230VAC15VA	230VAC 15VA	COLD	31,4	15,64	0,068	25
		HOT	-	14,41	0,063	80
C41230VAC15VA	230VAC 24VA	COLD	45,1	23,92	0,0154	23
		HOT	-	21,62	0,0154	100

Not: Please look catalogues for more details.

STANDARDS

- Standard tube connection G (BSP) (ISO 228-1) and other tube connections (NPT (ANSI 1.20.3)) are available on request.
- TORK solenoid valves 97/23/EC, are available for pressure equipment directive (PED) and 2006/95/ECC low voltage directive (LVD).

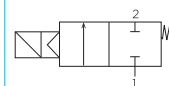

Solenoid Valve Symbol	Valve Type/ Order No	Connection Size	Orifice Size	Pressure		Kv	Seal			Weight
				min	max		NBR	Viton	EPDM	
	SX1020	G	mm	Bar	Bar	Lt/dk		Option		kg
	SX1020.00	1/8"	1,8	0	16	1,6	✓	✓	✓	0,36
	SX1020.00	1/8"	2,5	0	12	3,2	✓	✓	✓	0,36
	SX1020.00	1/8"	3	0	10	4,6	✓	✓	✓	0,36
	SX1020.01	1/8"	1,8	0	16	1,6	✓	✓	✓	0,35
	SX1020.01	1/4"	2,5	0	12	3,2	✓	✓	✓	0,35
	SX1020.01	1/4"	3	0	10	4,6	✓	✓	✓	0,35

Explosion Proof General Purpose Solenoid Valve SX1020 Series (G3/8", G1/2", G3/4", G1")

GENERAL FEATURES

- Wide pressure range, flow rate and orifis options.
- Solenoid valves are used with filters.
- Solenoid valves can be mounted in any position without affecting its operation, coil to be used in a vertical position.
- It is applicable for natural gas, lpg, methan, butane, propane, gas, noncorrosive gas. These are applicable for valve usage
- Operating Temperature: -10 °C / +160 °C
- No pressure difference is required.

ELECTRICAL CHARACTERISTICS

Voltages Tolerance : AC -15%, +10% DC -5%, +10%
 Frequency : 50 Hz (60 Hz...)
 On request; Connector with LED, PWM Socket
 Specify coil voltage with order.

MATERIALS IN CONTACT WITH FLUID

Body : Brass
 Internal Parts : Stainless Steel, Brass
 Sealing : NBR on request ; EPDM, VITON
 Shading Ring : Copper (EN 12735-1)
 Seats, Core Tube, Springs: Stainless Steel

OPTIONS

- Female connection: BSP; (On request NPT)
- Manual use on request.
 - On request CR-Ni coating.
 - On request PTFE coating.
 - On request ATEX (exproof) coil.

TECHNICAL FEATURES

Max. Viscosity : 5°E (-37cST or mm2/s)
 Response Time : Opening Time : 400-1600 ms
 Closing Time : 1000-2000 ms

SEALS FEATURES

NBR : -10°C...+80°C
 EPDM : -10°C...+130°C
 VITON : -10°C...+160°C
 PTFE : -10°C...+160°C
 RUBY : -10°C...+160°C



NORMALLY CLOSED

2 WAY

PILOT OPERATED

$\Delta P=0,15$

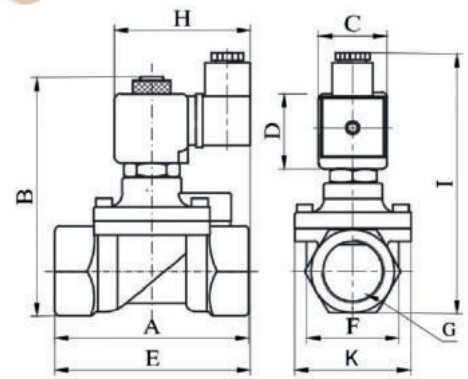

Dimensions (mm)									
G	A	B	C	D	E	F	K	H	I
3/8"	75	97	32	45	91,3	37,5	52	76	108
1/2"	79	100	32	45	92	39,8	52	76	110
3/4"	79	107,3	32	45	94	41,5	52	76	118
1	85	115	32	45	101	42,5	52	76	124

Coils	Nominal Values	Cold/ Hot	Inrush	Holding	Current (A)	Surface Temperature (°C)
C41012VDC18W	12VDC 18W	COLD	19,56	19,56	1,63	20
		HOT	14,52	14,52	1,21	106
C41024VDC18W	24VDC 18W	COLD	20,88	20,88	0,87	25
		HOT	14,64	14,64	0,61	116
C41110VDC18W	110VDC 18W	COLD	19,96	19,96	0,18	23
		HOT	13,56	13,56	0,123	115
C41012VAC15VA	12VAC 15VA	COLD	23,81	16,43	1,3	25
		HOT	-	15,86	1,262	79
C41024VAC15VA	24VAC 15VA	COLD	25,82	15,02	0,62	22
		HOT	-	13,91	0,57	81
C41110VAC15VA	110VAC 15VA	COLD	30,65	15,17	0,137	24
		HOT	-	13,96	0,126	80
C41230VAC15VA	230VAC 15VA	COLD	31,4	15,64	0,068	25
		HOT	-	14,41	0,063	80
C41230VAC15VA	230VAC 24VA	COLD	45,1	23,92	0,0154	23
		HOT	-	21,62	0,0154	100

Not: Please look catalogues for more details.

STANDARDS

- Standard tube connection G (BSP) (ISO 228-1) and other tube connections (NPT (ANSI 1.20.3)) are available on request.
- TORQ solenoid valves 97/23/EC, are available for pressure equipment directive (PED) and 2006/95/ECC low voltage directive (LVD).

Solenoid Valve Symbol	Valve Type/ Order No	Connection Size	Orifice Size	Pressure min/max		Kv	Seal			Weight kg
				Bar	Bar		NBR	Viton	EPDM	
	SX1020	G	mm	Bar	Bar	l/min		Option		
	SX1020.02	3/8"	12,5	0,15	16	38	✓	✓	✓	0,7
	SX1020.03	1/2"	14,5	0,15	16	62	✓	✓	✓	0,73
	SX1020.04	3/4"	17	0,15	16	85	✓	✓	✓	0,81
SX1020.05	1"	17	0,15	16	100	✓	✓	✓	0,99	