

Hava Firar Başlığı (BV,TL,RMRS Tip Onaylı) Air Vent Pipe Head(BV,TL,RMRS Type Approved)

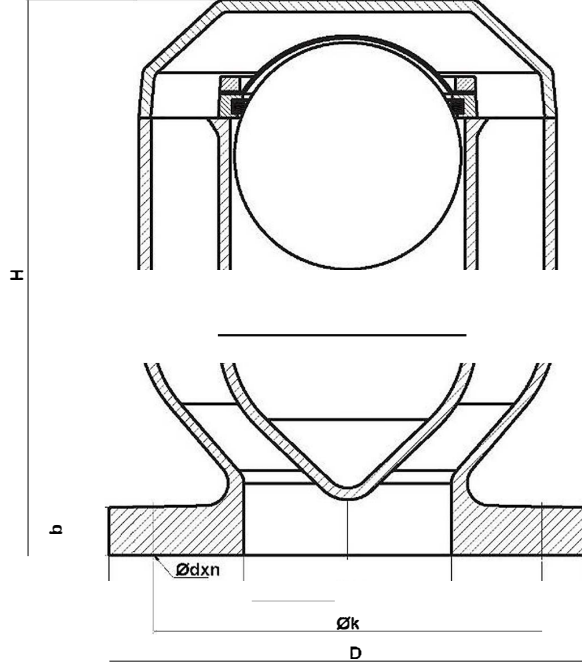

NO	PARÇA ADI	PART NAME	MATERIAL	DN	ØD	Øk	b	Ødxn	H	Kg
1	GÖVDE	BODY	GG25 / ALUMINIUM	DN50	165	125	20	18x4	160	5.35
2	TOP	BALL	P.E	DN65	185	145	20	18x4	195	7.7
3	O RİNG FLANŞLI	O RING HOLDER RING	RG5	DN80	200	160	20	18x8	218	9.6
4	O RİNG	O RING	NBR	DN100	220	180	22	18x8	260	13.2
5	TEL	STRAINER	316	DN125	250	210	22	18x8	305	19
6	TEL BASKI FLANŞI	STRAINER HOLDER RING	GG25 / ALUMINIUM	DN150	285	240	24	22x8	365	27.3
	CİVATA	BOLT	316	DN200	340	295	26	22x12	460	47
8	KAPAK	BONNET	GG25 / ALUMINIUM	DN250	405	355	28	26x12	570	78
				DN300	460	410	28	26x12	730	142
				DN350	520	470	30	26x16	815	195
				DN400	580	525	32	30x16	846	223

TEKNİK ÖZELLİKLER / TECHNICAL PROPERTY

TÜM DENİZ ARAÇLARININ (KARGO, TANKER, YÜK GEMİSİ, DUBA, YAT V.B) TANKLARININ HAVALANDIRMASINDA KULLANILABİLİR. THIS SYSTEM FOR ALL TANKS VENTILATION OF MARINE VEHICLES (CHEMICAL TANKERS, TUGS, YACHTS, CARGO SHIPS, BARGE... ETC)

UYGULAMA ALANLARI / APPLICATIONS

-BALLAST TANKS
-FUEL / OİL TANKS
-DIESEL / OİL TANKS
-FRESH WATER TANKS (TATLI SU TANKLARI)
-SEWAGE TANKS (PİS SU TANKLARI)
-BİLGE TANKS (SİNTİNE TANKLARI)

HAVA FIRARLARIMIZDA SERTİFİKALI İTHAL TOP BOYASINDA HEMPEL EPOXY BOYA KULLANILMIŞTIR. PAINT: HEMPEL EPOXY BALL IS CERTIFICATED