



## Type K03

DN 50 - 1000  
PN 16 - 100

## Gate Valve

Butt-Welded, Flanged

### Data Sheet

Edition: EN 9 / 2015

© MPOWER Engineering, a.s.  
Pod vinicí 2028/20, Modřany, 143 00 Praha 4, CZ  
T: +420 225 371 300, F: +420 225 371 325  
E: info@mpowergroup.eu, W: www.mpowergroup.eu

together we are strong  
[www.mpowergroup.eu](http://www.mpowergroup.eu)

## Content

Application .....	3
Technical description .....	3
Connection.....	3
Testing .....	3
Installation.....	3
Control .....	3
Operating data .....	4
Materials of main parts .....	5
Dimensions .....	7
Surfacing of the wedge and seats sealing surfaces .....	8
Accessories.....	9

## Copyright

All rights reserved. No content provided herein may be copied, distributed or otherwise reproduced without previous written approval of the company MPOWER Engineering, a.s.

© MPOWER Engineering, a.s., Praha 2015

## Contact

**MPOWER Engineering, a.s.**  
Pod vinicí 2028 / 20  
143 00 Praha 4 – Modřany, CZ

T: +420 225 371 300  
F: + 420 225 371 325  
E: [info@mpowergroup.eu](mailto:info@mpowergroup.eu)  
W: [www.mpowergroup.eu](http://www.mpowergroup.eu)



### Application

- Shut-off device designed to fully open or close the flow of the medium, not suitable for throttling or regulating
- **Operating agents**  
Water, steam, oil and oil products, natural gas, gas condensate, saturated and overheated steam, technological solutions, liquefied gases and other neutral and aggressive gases and liquids. The medium must not have a high content of solid and abrasive contaminants that can damage the sealing surface of the valve, or excessively wear inner surface of the gate valve, especially sealing surfaces of the seats and wedges
- **Industry**  
Energy, chemicals, petrochemicals, gas metallurgy
- **Environment**  
Normal, tropical, explosive, seismic

### Technical description

- Yoke gate valve with full flow
- Body and lid made of cast steel
- Non-rotating rising stem, non-rising handwheel.
- Valves with DN 150 or more have a spindle nut with ball bearing, which reduces torque and improves the gate valve control
- Seats in the body and sealing surfaces of the wedge are hardfaced with alloy: 13Cr, Stellite 6
- Flexible wedge of the gate valve (see picture) increases the adhesion to the seats and ensures higher tightness of the gate valve
- Tightness class "A" in both directions



- Gland space packing and sealing between the body and the lid is made of asbestos-free material
- Sealing between the body and the lid is made of expanded graphite with reinforcement made of stainless steel 304
- Gland packing material is expanded graphite
- Gate valves can be equipped with a back seat, which makes it possible to additionally seal the leaks around the stem during operation
- Valves without a bypass for the full pressure gradient (on demand, they can be equipped with a bypass (with one or two valves))
- Flanged gate valves with integral flanges and body

### Connection

- Gate valves with but-welded ends according to EN-

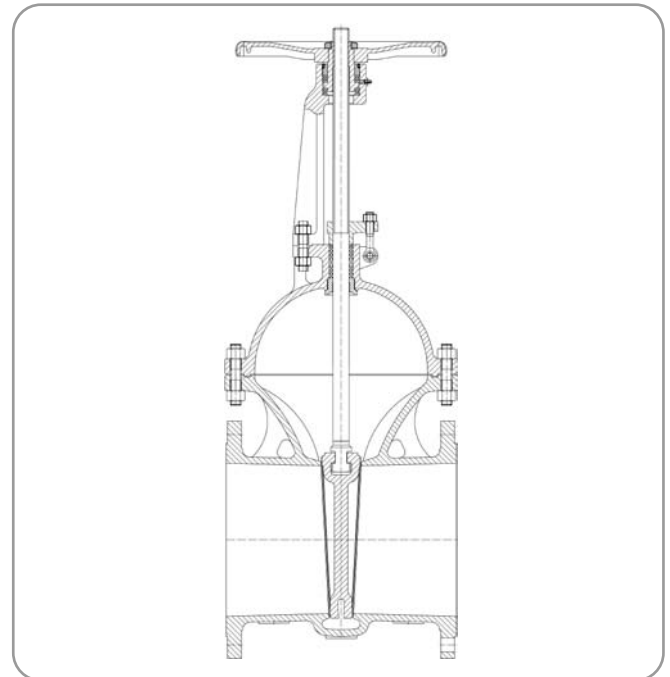

12627, flanged according to EN-1092-1, or on demand

- Building lengths of the gate valves according to EN-558-1
- On demand, the gate valves can be delivered also with other building length and with connection according to different standards (e.g. ASME, GOST, API atd).

### Testing

- Gate valves are tested with water for strength, impermeability, operational capacity and tightness depending on the operating parameters and material of the body according to EN-12266
- Minimum pressure for the strength test  $1.5 \times P_N$
- Minimum pressure for the leakage test  $1.1 \times P_N$

### Installation

- Gate valves are installed in any position regardless of the direction of flow of the working fluid
- For electrically actuated valves, it is necessary to ensure compliance with the manufacturer's instructions of the actuator

### Control

- Hand wheel (when closing rotates clockwise)
- Front gear
- Electric servo motor (in the end position „closed“ is switched off from the torques, in the position „otevřeno“ is switched off from the set position)
- On demand, the gate valves can be delivered only with the preparation for connection to the actuator. Connection dimensions according to ISO 5210, form B1

**Operating data**

Material of body	PN	Working pressure MPa / Working temperature °C												
		100	150	200	250	300	350	400	425	450	500	525	550	595
1.0619 (WCB)	16	1,46	1,43	1,38	1,32	1,22	1,17	1,09	0,91	-	-	-	-	-
	25	2,29	2,23	2,16	2,06	1,91	1,82	1,7	1,42	-	-	-	-	-
	40	3,66	3,57	3,46	3,29	3,06	2,92	2,72	2,27	-	-	-	-	-
	63	5,77	5,62	5,45	5,19	4,81	4,59	4,29	3,57	-	-	-	-	-
	100	9,15	8,92	8,65	8,23	7,64	7,29	6,81	5,67	-	-	-	-	-
LC1	16	1,47	1,42	1,4	1,36	1,33	1,27	1,15	-	-	-	-	-	-
	25	1,84	1,77	1,74	1,7	1,66	1,59	1,44	-	-	-	-	-	-
	40	3,68	3,55	3,49	3,4	3,32	3,18	2,89	-	-	-	-	-	-
	63	5,79	5,59	5,49	5,35	5,22	5,0	4,55	-	-	-	-	-	-
	100	9,19	8,87	8,72	8,5	8,29	7,94	7,22	-	-	-	-	-	-
1.7357 (WC6)	16	1,63	1,57	1,51	1,46	1,35	1,27	1,15	1,11	1,07	0,8	0,57	0,4	0,19
	25	2,54	2,45	2,37	2,28	2,11	1,98	1,8	1,73	1,67	1,24	0,9	0,63	0,31
	40	4,06	3,93	3,79	3,64	3,38	3,18	2,89	2,77	2,67	1,99	1,43	1,0	0,49
	63	6,4	6,19	5,96	5,74	5,33	5,0	4,55	4,36	4,2	3,14	2,26	1,58	0,76
	100	10,16	9,82	9,47	9,11	8,46	7,94	7,22	6,92	6,67	4,98	3,58	2,51	1,21
1.4408 (CF8M)	16	1,33	1,22	1,13	1,05	1,0	0,96	0,93	0,92	0,91	0,86	0,8	0,76	0,64
	25	2,08	1,9	1,76	1,65	1,56	1,5	1,45	1,44	1,42	1,35	1,25	1,12	0,99
	40	3,33	3,04	2,82	2,63	2,5	2,4	2,36	2,32	2,3	2,28	2,16	2,0	1,59
	63	5,25	4,79	4,43	4,15	3,93	3,79	3,66	3,62	3,59	3,4	3,14	2,97	2,5
	100	8,33	7,6	7,04	6,59	6,24	6,01	5,81	5,75	5,69	5,4	4,99	4,72	3,95
1.7390 (A217 WC9)	16	1,63	1,58	1,54	1,46	1,35	1,27	1,15	1,11	1,07	0,88	0,68	0,49	0,27
	25	2,54	2,48	2,41	2,29	2,11	1,98	1,8	1,73	1,67	1,37	1,07	0,76	0,38
	40	4,07	3,96	3,85	3,66	3,38	3,18	2,89	2,77	2,67	2,19	1,71	1,21	0,61
	63	6,41	6,24	6,06	5,76	5,33	5,0	4,55	4,36	4,2	3,46	2,69	1,91	0,92
	100	10,17	9,9	9,63	9,14	8,46	7,94	7,22	6,92	6,67	5,49	4,28	3,03	1,45
1.7386 (A217 C12A)	16	1,63	1,58	1,54	1,46	1,35	1,27	1,15	1,11	1,07	0,89	0,81	0,79	0,65
	25	2,54	2,48	2,41	2,29	2,11	1,98	1,8	1,73	1,67	1,39	1,27	1,23	0,99
	40	4,07	3,96	3,85	3,66	3,38	3,18	2,89	2,77	2,67	2,23	2,04	1,97	1,57
	63	6,41	6,24	6,06	5,76	5,33	5,0	4,55	4,36	4,2	3,51	3,21	3,1	2,46
	100	10,17	9,9	9,63	9,14	8,46	7,94	7,22	6,92	6,67	5,57	5,09	4,92	3,86

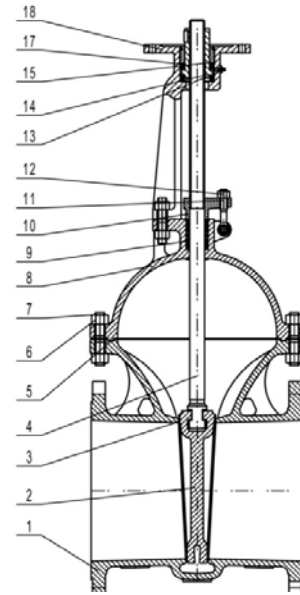
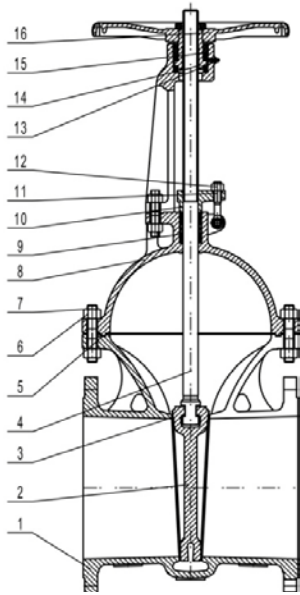

**Materials of main parts**

Pos.	Name	Materials					
1	<b>Body</b>	1.0619 (A216 WCB)	A352 LC1	1.7357 (A217 WC6)	1.4408 (A351 CF8M)	1.7390 (A217 WC9)	1.7386 (A217 C12A)
2	<b>Wedge</b>	1.0619 (A216 WCB)	A352 LC1	1.7357 (A217 WC6)	1.4408 (A351 CF8M)	1.7390 (A217 WC9)	1.7386 (A217 C12A)
3	<b>Seat</b>	13Cr/Stellite	13Cr/Stellite	13Cr/Stellite	13Cr/Stellite	Stellite	Stellite
4	<b>Stem</b>	X20Cr13+QT	X20Cr13+QT	X20Cr13+QT	A182 F316	25CrMoV	25CrMoV
5	<b>Gasket</b>	Graphite + stainless steel 304	Graphite + stainless steel 304	Graphite + stainless steel 304	Graphite + stainless steel 316	Graphite + stainless steel 304	Graphite + stainless steel 304
6	<b>Nut</b>	A194 2H	A194 7	A194 4	A194 8M	A194 4	A194 4
7	<b>Eyebolt</b>	A193 B7	A193 B7	A193 B16	A193 B8M	A193 B16	A193 B16
8	<b>Bonnet</b>	1.0619 (A216 WCB)	A352 LC1	1.7357 (A217 WC6)	1.4408 (A351 CF8M)	1.7390 (A217 WC9)	1.7386 (A217 C12A)
9	<b>Packing ring</b>	Graphite	Graphite	Graphite	Graphite	Graphite	Graphite
10	<b>Packing gland</b>	1.0619 (A216 WCB)	A352 LC1	1.7357 (A217 WC6)	1.4408 (A351 CF8M)	1.7390 (A217 WC9)	1.7386 (A217 C12A)
11	<b>Eye bolt</b>	A193 B7	A193 L7	A193 B16	A193 B8M	A193 B16	A193 B16
12	<b>Haxegon nut</b>	A194 2H	A194 7	A194 4	A194 8M	A194 4	A194 4
13	<b>Lubricall fitting</b>	Cu	Cu	Cu	Cu	Cu	Cu
14	<b>Stem nut</b>	GGG40.3	GGG40.3	GGG40.3	GGG40.3	Cu	Cu
15	<b>Threaded nut</b>	C.S	C.S	C.S	S.S	C.S	C.S
16	<b>Handwheel</b>	steel (KTH 330-08)	steel (KTH 330-08)	steel (KTH 330-08)	steel (KTH 330-08)	steel (KTH 330-08)	steel (KTH 330-08)
17	<b>Bearing</b>	C.S	C.S	C.S	S.S	C.S	C.S
18	<b>Flange</b>	1.0460(A105)	1.0460(A105)	1.0460(A105)	1.0460(A105)	1.0460(A105)	1.0460(A105)

Gate valves K03, DN 50-600, PN 16– 100, with hand wheel

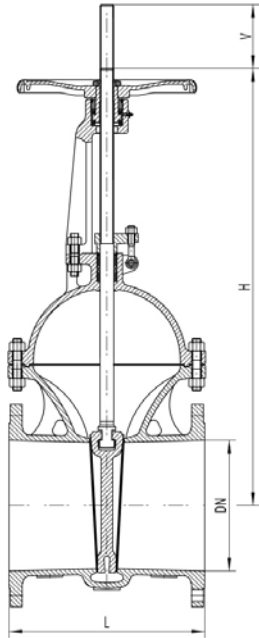

Flanged type

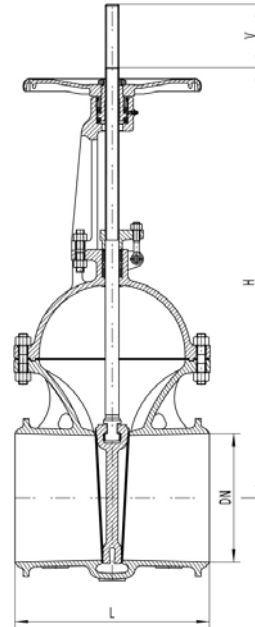

Welded type

Gate valves K03, DN 50-1000, PN 16– 100, with electrical actuator and gears

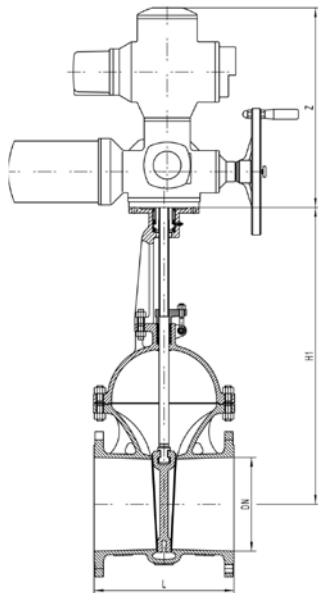

Gate valve with actuator

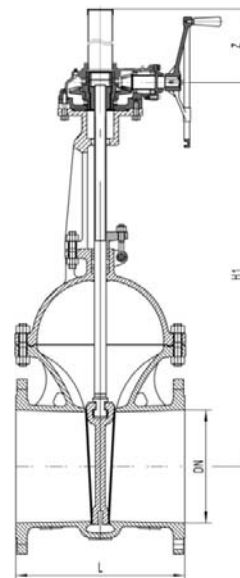

Gate valve with gear

Notes: Dimension "Z": acc. to manufacturer's specification of the selected valve control type.

**Dimensions**

DN	PN	L mm	H mm	V mm	H1 mm	ISO 5210	Mk Nm	m kg	
								FL	BW
50	16	250	330	70	300	F10	18	18	15
65		270	365	83	335	F10	25	27	21
80		280	405	96	370	F10	36	32	25
100		300	480	120	450	F10	52	46	38
125		325	535	145	570	F10	70	61	52
150		350	625	170	650	F10	102	82	70
200		400	780	220	820	F14	132	145	118
250		450	930	270	880	F14	215	235	210
300		500	1050	320	1010	F14	300	330	300
350		550	1190	366	1150	F14	420	390	370
400		600	1375	417	1310	F16	600	620	576
500		700	1660	518	1610	F16	788	947	870
600		800	1945	620	1890	F25	1380	1458	1200
700		900	2360	690	2210	F25	2010	2100	1810
800		1000	2980	790	2900	F30	2200	2900	2400
900		1100	3150	970	3100	F35	3200	4600	4260
1000	1200	3500	1071	3450	F35	4200	5700	5000	
50	25	250	330	70	300	F10	18	20	15
65		270	365	83	335	F10	27	28	21
80		280	405	96	370	F10	38	34	25
100		300	480	120	450	F10	55	50	38
125		325	535	145	570	F10	75	67	53
150		350	625	170	650	F10	105	90	71
200		400	780	220	820	F14	180	156	126
250		450	930	270	880	F14	290	250	210
300		500	1050	320	1010	F14	420	360	310
350		550	1190	366	1150	F16	580	420	370
400		600	1375	417	1310	F16	850	640	590
500		700	1660	512	1610	F16	920	1021	870
600		800	1945	614	1890	F25	1680	1590	1200
700		900	2360	690	2210	F25	2200	2300	1810
800		1000	2980	790	2900	F30	2650	3100	2495
900		1100	3150	970	3100	F35	4800	4860	4260
1000	1200	3500	1071	3450	F35	5800	5700	5000	
50	40	250	330	70	300	F10	18	20	15
65		290	365	83	340	F10	28	28	22
80		310	405	96	375	F10	38	36	28
100		350	490	120	460	F10	82	62	40
125		400	540	145	540	F10	100	85	71
150		450	660	170	650	F14	150	125	110
200		550	820	220	800	F14	260	220	195
250		650	930	270	890	F14	412	310	270
300		750	1050	320	1010	F16	590	420	370
350		850	1190	366	1150	F16	780	560	510
400		950	1360	417	1310	F25	955	730	680
500		1150	1515	512	1610	F25	1450	1450	1000
600		1350	1660	614	1895	F30	2600	2400	1580

DN	PN	L mm	H mm	V mm	H1 mm	ISO 5210	Mk Nm	m kg	
								FL	BW
50	63	250	370	70	340	F10	35	28	21
65		280	390	83	360	F10	45	45	28
80		310	450	96	420	F10	65	56	31
100		350	500	120	480	F10	100	80	70
125		400	570	145	550	F14	170	114	94
150		450	660	170	630	F14	230	198	162
200		550	855	219	775	F14	440	345	270
250		650	1015	267	910	F16	720	490	430
300		750	1165	318	1030	F25	1100	700	630
350		850	1305	356	1278	F25	1300	860	700
400		950	1420	404	1360	F30	1900	1134	820
500		1150	2060	493	2000	F35	5300	1800	1530
600		1350	2300	598	2250	F40	6800	1920	1620
50		100	250	370	70	340	F10	42	30
65	280		410	83	360	F10	53	48	28
80	310		450	96	420	F10	75	70	40
100	350		500	120	480	F14	148	95	85
125	400		570	145	550	F14	238	160	125
150	450		660	170	630	F14	385	250	226
200	550		855	219	775	F16	710	420	350
250	650		1015	267	910	F25	1280	620	513
300	750		1165	318	1030	F25	1580	950	780
350	850		1235	356	1278	F30	2190	1215	725
400	950		1420	404	1360	F35	2870	1500	1200
500	1150		2060	493	2000	F35	5200	1960	1600
600	1350		2300	598	2250	F40	8200	2200	1780

### Surfacing of the wedge and seats sealing surfaces

Seats in the body and sealing surfaces of the wedge are hardalloyed according to the body material and the valves dimensions:

PN	DN	Body material	Surfacing type	Surfacing on the wedge	Surfacing on the seat
16-40	50-150	WCB, LC1	TRIM 1	13Cr	13Cr
	200-1000	WCB, LC1	TRIM 8	13Cr	Stellite 6
	50-600	CF8	TRIM 8	13Cr	Stellite 6
	50-600	WC6	TRIM 5	Stellite 6	Stellite 6
63-100	50-600	WCB, WC6	TRIM 5	Stellite 6	Stellite 6



**Accessories**

On demand, the following accessories can be ordered for the valves:

- Valve bypass (with one or two shut-off valves)

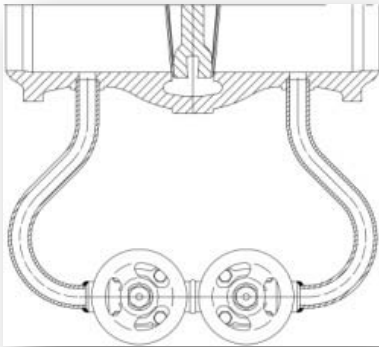
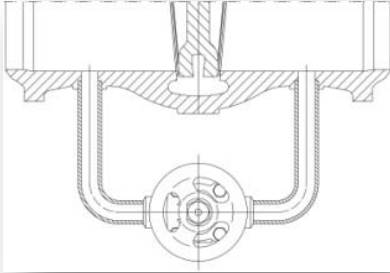

- Pressurized stuffing box for the valves used for vacuum

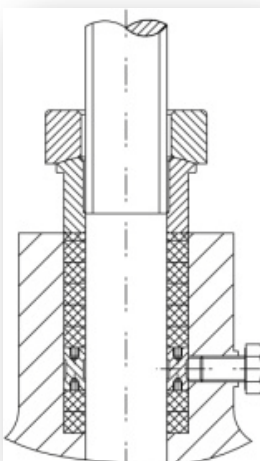

- Back Seat

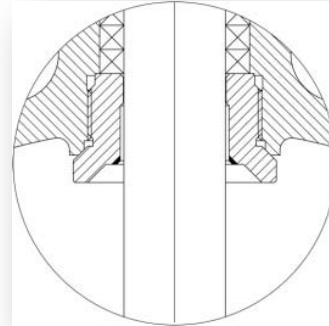

- Remote control including stands, chains and wheels

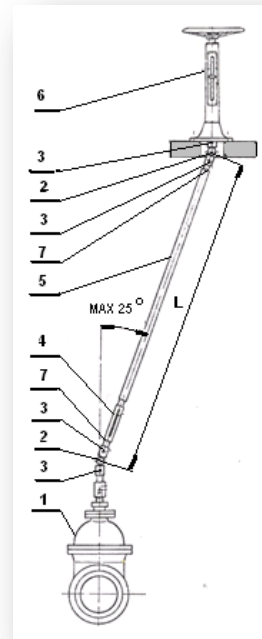

- Locking device

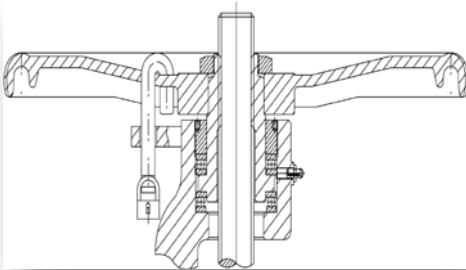

- Position transmitters (only open or closed, or both positions: open and closed)

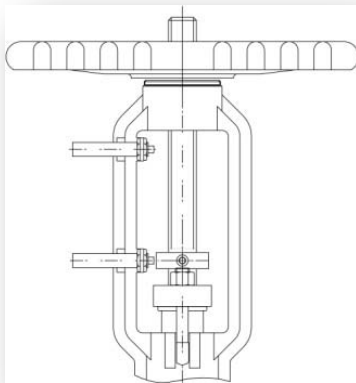

- Extension rings of forged steel 16Mo3, 13Cr, Steel 20 (Сталь 20) and other carbon low-alloyed or high-alloyed steel

