

310F1

AISI 316L high pressure filters, suitable for gas and liquid



FEATURES

Filter for inlet pressure up to 220 bar (3190 psi) in the standard version.

Available connections

G3/4-M;
G1-M;
3/4" NPT-M;
1" NPT-M.

Other connections available on request.

Replaceable filter element: 5 μm or 50 μm
or coalescing(0,01 μm /99,99%) .

The product complies with the directive
2014/68/EU (PED).

SPECIFICATIONS

Filter weight: ~11,33 Kg (24,9 lb)

Operating temperature: -20 °C ÷ +60 °C (-4 °F ÷ +140 °F) for standard version

Degree of protection: IP66

Bowl capacity: 220cc (7.43 fluid ounces)

Acetylene version: maximum operating pressure 15 bar

MATERIALS

Body: AISI 316L

Bowl: AISI 316L

Internal parts: AISI 316L

O-Ring: FPM or EPDM according to the fluid (other compounds available on request)

Filter cartridges 5 and 50 µm: sintered AISI 316L

SPARE PARTS

Filter cartridges

Complete kit: filter cartridge, O-rings

generating the product code

Filtro alta pressione AISI 316L/ High pressure AISI 316L filter			
AA BB CC D EE FF			
AA	Attacchi / Connections	QM	G3/4-M
		RM	G1-M
BB	Pressione d'ingresso / Inlet pressure	J0	PS 220bar
CC	Tipologia di fluido / Type of fluid	98	EPDM
		99	FPM
D	Grado di filtrazione/ Filtration rate	C	5µm
		H	50µm
EE	Marchiato / Marked	I0	Insert Deal
FF	Accessori / Accessories	00	Nessun accessorio / No accessories

ESEMPIO COMPOSIZIONE CODICE

310F1# RM J0 99 H I0 00

RM : G1-M

J0 : PS 220bar

99 : FPM

H : 50µm

I0 : Insert Deal

00 : Nessun accessorio / No accessories

tecnicah drawings (all dimensions in mm)

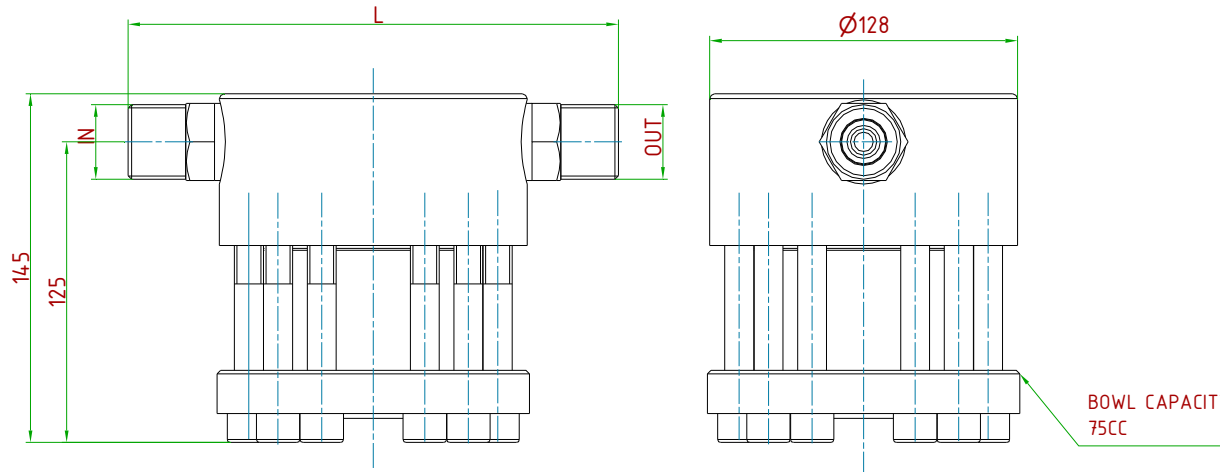

MODEL	IN/OUT	L [mm]
110F1/310F1 G3/4"	G3/4"-M	~196
110F1/310F1 3/4"NPT	3/4"NPT-M	~196
110F1/310F1 G1"	G1"-M	~204
110F1/310F1 1"NPT	1"NPT-M	~204